

## Short Circuit Current Analysis and Recloser Coordination in 20 kV Distribution Network Using Manual Calculation and ETAP Software Simulation

Riswanda

*Electrical Engineering*

*Malikussaleh University*

Lhokseumawe, Indonesia

riswanda.210150072@mhs.unimal.ac.id

Raihan Putri

*Electrical Engineering*

*Malikussaleh University*

Lhokseumawe, Indonesia

raihan@unimal.ac.id

Muchlis Abdul Muthalib

*Electrical Engineering*

*Malikussaleh University*

Lhokseumawe, Indonesia

muchlis.abd@unimal.ac.id

**Abstract—** This study aims to analyze the performance of reclosers in improving the reliability of the 20 kilovolt distribution network at PT PLN (Persero) UP3 Lhokseumawe. The research focuses on optimizing the placement and delay time settings of reclosers based on fault current and network impedance. A comparative method was used involving manual calculations and simulation using ETAP 16.0.0 software. The object of study is the CD 12 feeder. The simulation evaluates fault currents and the corresponding recloser delay times at several bus locations. Results show that the closer the fault location to the power source, the higher the short-circuit current, which leads to shorter recloser operating time. Conversely, longer distances result in lower fault currents and longer delay settings. The analysis confirms that proper coordination and parameter settings significantly improve system protection and recovery. Moreover, differences between manual and simulation results emphasize the importance of digital tools in distribution network analysis. The novelty of this study lies in its comparative analysis between manual and ETAP-based calculations specifically applied to the CD 12 feeder at PT PLN UP3 Lhokseumawe. Unlike previous works that focused only on either manual or simulation-based approaches, this research integrates both methods to highlight practical implications in real distribution protection systems.

**Keywords—** Recloser configuration, fault current analysis, 20 kilovolt distribution, ETAP simulation, system reliability.

### I. INTRODUCTION

The power system in the 20 kV distribution network plays a crucial role in ensuring the smooth supply of electrical energy to end consumers. However, this network often faces various disturbances that can cause power outages, which impact system reliability. Therefore, protection devices are needed that can detect and isolate disturbances quickly to prevent the disturbance from spreading and causing damage to other devices in the system [1]. In this context, reclosers are an effective solution because they can handle temporary outages through automatic disconnection and reconnection mechanisms. This feature not only shortens the duration of the outage but also reduces its impact [2]. The effectiveness of a recloser becomes more apparent when it is properly placed. Proper location can improve protection coordination and speed up overall system recovery [3].

The success of a recloser is greatly influenced by its parameter settings, particularly in coordination with other protective equipment such as overcurrent relays and fuses. This adjustment process must be carried out carefully to prevent disruptions [4]. Reclosers allow the network to cope with temporary disturbances such as lightning or tree strikes without permanently cutting off power. Their automatic mechanisms can reduce the duration of disruptions and increase the reliability of supply to customers [5].

Another function of a recloser is network segmentation. When a disruption occurs, the recloser can bypass only the affected section, so not all customers feel the impact. This is a key strategy in maintaining supply continuity [6]. Coordination time between the recloser and other protective equipment is crucial to the outcome. The setup must ensure that the equipment closest to the fault location is operated first [7]. Using simulation software such as ETAP in recloser planning can help identify critical points and optimize protection settings. This simulation allows for more accurate technical decision-making in distribution systems [8].

The increasing complexity of distribution networks requires adaptive protection systems to maintain operational reliability. Reclosers provide a reliable solution for handling momentary disturbances without compromising overall network reliability [9]. Proper recloser placement requires accurate fault data and network load profiles. Using simulation software such as ETAP, strategic recloser placement analysis is performed to improve protection effectiveness and system stability [10].

The protective coordination system between reclosers and other components such as fuses and sectionalizers requires precise configuration. The goal is to ensure the system responds selectively to faults while avoiding further network damage [11].

The automatic recloser function minimizes the need for manual interruptions during temporary power outages. The recovery process is faster and operational efficiency for the company is improved [12].

Recloser placement depends on several factors, including line length, number of branches, and load characteristics. The goal of this adjustment is to allow the device to handle the disturbance most effectively [13]. The integration of reclosers into smart grid systems has advanced the digital distribution

process. Modern reclosers have digital communication capabilities to monitor and control network operations throughout the system [14].

Reclosers are able to adapt to changes in power generated by renewable energy sources. This capability helps maintain the stability of the 20 kV distribution system even under varying load conditions [15]. Coordination of the recloser's operating time with other protective devices is a fundamental requirement for preventing operational errors. The successful response of the system to a fault depends on this configuration [16].

## II. RESEARCH METHODS

### A. Distribution Network Model in ETAP

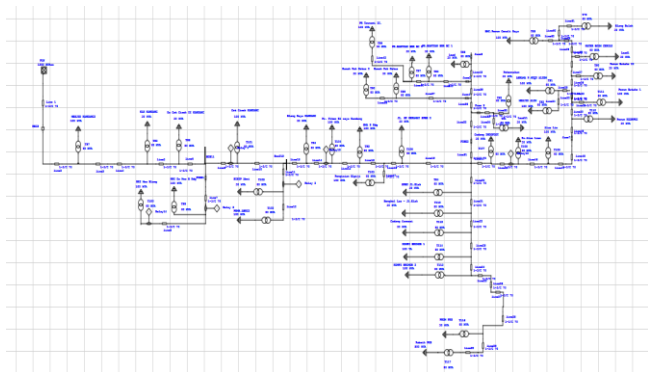

The ETAP network diagram used in this study represents the CD 12 feeder configuration in the 20 kV distribution system at PT PLN (Persero) UP3 Lhokseumawe. The network model was built in detail by including the main components, namely the power source from the substation, a 60 MVA power transformer with a voltage of 150/20 kV, the main distribution line, and branches to the load buses. The network also includes technical data on the line in the form of a 150 mm<sup>2</sup> AAAC conductor type with a total length of 14.487 km and its impedance parameters, both positive, negative, and zero.

Furthermore, the network model incorporates protective devices in the form of reclosers placed at strategic points to safeguard the system in the event of a disruption. This network representation allows for more accurate short-circuit current analysis at each bus. The ETAP calculations are then used to evaluate recloser timing, allowing for more effective protection coordination.

Network modeling in ETAP is the main basis of the research because it is able to show the real conditions of the CD 12 feeder. Thus, a comparison between the results of manual calculations and simulation results can be carried out comprehensively, while also showing its practical implications for the reliability of the 20 kV distribution protection system.

### B. ETAP Simulation Stages

The simulation workflow using ETAP 16.0.0 is carried out in the following stages:

1. System data input: Entering transformer, line, feeder length, impedance, and load data.
2. Creating a one-line diagram: Describing the CD 12 feeder configuration and its protection components.
3. Determining protection parameters: Setting the setting current ( $I_{set}$ ), TMS value, and recloser characteristic curve.
4. Short circuit analysis: Running a simulation to calculate three-phase fault currents on several buses.
5. Recloser runtime analysis: Determining the operating time based on the current-time curve and the fault current simulation results.
6. Comparison of results: Comparing the manual calculation results with the ETAP simulation results and analyzing the differences between the two.

### C. Calculating Recloser Settings

Feeder setting value 20 kV

$$I_{set} = 1,05 \times I_{beban} \quad (2.1)$$

Note:

$I_{set}$  = Arus setting

$I_{beban}$  = Arus beban

Determining the standard relay setting time, or Time Multiple Setting (TMS), is based on calculations using a formula for the relationship between time and current. The formula can vary depending on the design of each relay manufacturer. In this case, the time and current calculations refer to the following British Standard.

$$T_d = \frac{0,14 \times T_{ms}}{\left(\frac{I_f}{I_{set}}\right)^{0,02} - 1} \quad (2.2)$$

Note:

$T_d$  = Delay time (s)

$T_{ms}$  = Time multiple setting

$I_f$  = Short circuit current

$I_{set}$  = Setting current

### D. Sequence Network Method

In this method, an unbalanced three-phase system is decomposed into three separate networks: zero-sequence, negative-sequence, and positive-sequence. After that, an impedance matrix or admittance matrix can be constructed as needed. In the process of calculating known impedances, there are three types of impedances based on the sequence, namely:

- a. Positive sequence impedance (Z1), is the impedance that only positive sequence currents pass through.
- b. Negative sequence impedance (Z2), is the impedance that only negative sequence currents pass through.
- c. Zero sequence impedance (Z0), is the impedance that only passes through zero sequence current.

1. Source impedance

To obtain the source impedance value on the 20 kV bus side, the first step that must be taken is to calculate the source impedance on the 150 kV bus side as well as on the 150 kV main bus, using the following formula

$$X_s = \frac{kV^2}{MVA} \tag{2.3}$$

Note :

- Xs = source impedance (Ohm)
- kV = primary side voltage of power transformer (kV)
- MVA = short circuit data on 150 KV bus (MVA)

To obtain the short-circuit current on the 20 kV side, the initial step is to convert the source impedance from the 150 kV side to the 20 kV side. This conversion process is carried out by calculating the source impedance on the secondary side using the following formula:

$$X_s \text{ (sisi 20 kV)} = \frac{kV^2}{kV^2} \times X_s \text{ (sisi 150 kV)} \tag{2.4}$$

2. Transformer Impedance

When calculating transformer impedance, only the reactance component is considered, while the resistance is ignored due to its relatively small value. Transformer reactance in ohms can be calculated as follows:

The first step is to determine the ohm value equivalent to 100% for a 20 kV transformer, using the following formula:

$$X_t \text{ (pada \%)} = \frac{kV^2}{MVA_{trafo}} \tag{2.5}$$

Note:

- Xt = Power transformer impedance (Ohm)
- kV<sup>2</sup> = Secondary side voltage of power transformer (kV)
- MVA = Power transformer power capacity (MVA)

3. Calculation of Feeder Impedance

Calculating the impedance of a feeder line depends on the impedance value per kilometer of the cable being analyzed. This value is influenced by several factors, such as the type of conductor, the cable length, the material it is made of, and the conductor's cross-sectional area.

Positive sequence and negative sequence impedance.

$$Z_1 = \text{Length of the feeder (Km)} \times Z_1 \tag{2.6}$$

Note :

$$Z_1 = \text{Positive sequence impedance (Ohm)}$$

4. Calculation of Equivalent Impedance

In calculating the equivalent impedance, what is calculated is the magnitude of the positive sequence impedance (Z1 eq), negative sequence (Z2 eq), and zero sequence (Z0 eq) from the fault point to the source..

$$Z_{eq} = Z_{sal} + Z_T + Z_1 \tag{2.7}$$

Note:

- Z<sub>eq</sub> = Equivalent impedance
- Z<sub>sal</sub> = Line impedance
- Z<sub>T</sub> = Transformer impedance
- Z<sub>1</sub> = Source impedance

5. Calculation of feeder impedance in units per unit (pu)

$$I_{base} = \frac{MVA}{\sqrt{3} \times kV_{base}} \tag{2.8}$$

$$Z_{base} = \frac{kV_{base} \cdot \sqrt{3}}{I_{base}} \tag{2.9}$$

6. 3-phase short circuit current disturbances can be found using the following formula:

$$I_{hs \text{ 3fasa (pu)}} = \frac{E_a}{Z_{1eq}} \tag{2.10}$$

$$I \text{ 3fasa (A)} = I_{3fasa \text{ (pu)}} \times I_{base} \tag{2.11}$$

Note:

- His (pu) = Short circuit current per unit
- E<sub>a</sub> = Source voltage assumption
- Z<sub>eq</sub> = Equivalent impedance

E. Flowchart

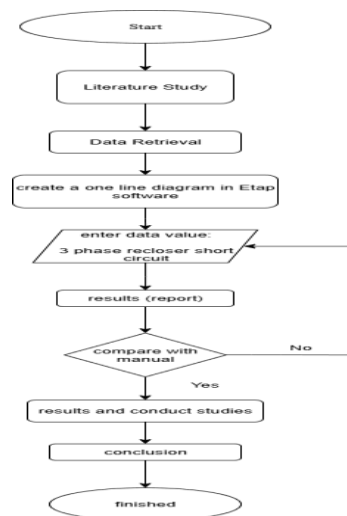

Fig. 1. Flowchart

III. RESULT AND DISCUSSION

1. Short Circuit Analysis

In this short circuit analysis, two methods were used, namely using manual calculations and simulations using ETAP 16.0.0 software.

The data on the transformer can be seen as follows :

- 1. Short circuit power
  - P<sub>hs</sub> = 1200 MVA
- 2. Power Transformer Rating
  - Power = 60 MVA
  - Voltage = 150/20 kV
  - Primary voltage = 150 kV
  - Secondary voltage = 20 kV
  - Impedance = 12,5 %
  - Channel length = 14,487 Km

Based on the information received, the type of cable used in the CD 12 feeder is an A3C type cable measuring 150 mm<sup>2</sup> with a value of Z<sub>1</sub> = Z<sub>2</sub> (0,2162 + j0,3305 Ohm/Km) dan Z<sub>0</sub> (0,3631 + j1,6180).

To compare the results of manual calculations using ETAP software, the author took some data from the number of channels on the CD 12 feeder.

The impedance value of the CD 12 feeder can be calculated as follows :

$$Z_1 = Z_2 = (R_1 + jX_1) \times \text{jarak}$$

$$Z_0 = (R_0 + jX_0) \times \text{jarak}$$

1. Calculating the Impedance of the CD 12 Feeder on Bus 77

$$Z_1 = Z_2 \text{ (AAAC 150 mm}^2\text{)} \times \text{jarak}$$

$$= (0,2162 + j0,3305 \text{ Ohm/Km}) \times 0,8 \text{ KM}$$

$$= 0,172 + j0,264 \text{ Ohm}$$

$$Z_0 = \text{(AAAC 150 mm}^2\text{)} \times \text{jarak}$$

$$= (0,3631 + j1,6180 \text{ Ohm/Km}) \times 0,8 \text{ KM}$$

$$= 0,290 + j1,294 \text{ Ohm}$$

Using the same calculation method, the results of the line impedance calculations at the fault point of each network bus on the CD 12 feeder can be seen in the table below :

Table 1. Results of calculations of positive, negative and zero sequence feeder impedance

Bus	Jarak (Km)	Z <sub>1</sub> =Z <sub>2</sub>		Z <sub>0</sub>	
		R	jX	R	jX
13	0,25	0,054	0,082	0,090	0,404
15	0,25	0,054	0,082	0,090	0,404
17	0,65	0,140	0,214	0,236	1,051
26	0,75	0,162	0,247	0,272	1,21
77	0,8	0,172	0,264	0,290	1,294

2. Calculating Feeder Impedance in Units Per Unit (PU)

The following is a calculation for the impedance on bus 77.

- a. Calculate the impedance of the feeder to the PU unit

$$X_s = \frac{kV \text{ (sisi primer)}^2}{MVA_{sc}} = \frac{150^2}{1200} = 18,7500 \text{ j Ohm}$$

$$\text{On the side 20 Kv} = \frac{20^2}{150^2} \times 18,75 = 0,3333 \text{ j Ohm}$$

b. Calculating transformer reactance

$$X_t = \frac{kV^2}{MV_{trafo}} \times \% \text{ trafo} = \frac{20^2}{60} \times 12,5\% = 0,8333 \text{ j Ohm}$$

c. Calculating I<sub>base</sub> and Z<sub>base</sub>

$$I_{base} = \frac{MVA}{\sqrt{3} \times kV_{base}} = \frac{100}{\sqrt{3} \times 20} = \frac{100}{34,64} = 2,8868 \text{ kA}$$

$$Z_{base} = \frac{kV_{base} \cdot \sqrt{3}}{I_{base}} = \frac{20 \cdot \sqrt{3}}{2,8868} = \frac{11,5471}{2,8868} = 3,9999 \text{ Ohm}$$

d. Calculate the R and X values per unit (PU)

On bus 77

$$Z_{1eq} = R + X + X_s + X_t$$

$$= 0,172 + j0,264 + j0,3333 + j0,8333$$

$$= 0,172 + j1,430$$

$$R_{pu} = \frac{R}{Z_{base}} = \frac{0,172}{3,9999} = 0,043 \text{ pu}$$

$$X_{pu} = \frac{X}{Z_{base}} = \frac{1,430}{3,9999} = 0,357 \text{ pu}$$

$$Z_{0eq} = R + X + X_s + X_t$$

$$= 0,290 + j1,294 + j0,3333 + j0,8333$$

$$= 0,290 + j2,460$$

$$R_{pu} = \frac{R}{Z_{base}} = \frac{0,090}{3,9999} = 0,072 \text{ pu}$$

$$X_{pu} = \frac{X}{Z_{base}} = \frac{1,570}{3,9999} = 0,615 \text{ pu}$$

By using the same method, the results of the network impedance values for each bus in units per unit (pu) in the CD 12 feeder are obtained, which can be seen in the table below:

Table 2. The results of the calculation of the positive, negative and zero sequence impedance of the CD 12 feeder in units per unit.

Bus	Jarak (km)	Z <sub>1eq</sub> = Z <sub>2eq</sub>		Z <sub>0eq</sub>		Z <sub>1eq</sub> = Z <sub>2eq</sub>		Z <sub>0eq</sub>	
		R	jX	R	jX	R (pu)	jX (pu)	R (pu)	jX (pu)
13	0,25	0,054	1,248	0,090	1,570	0,013	0,312	0,022	0,392
15	0,25	0,054	1,248	0,090	1,570	0,013	0,312	0,022	0,392
17	0,65	0,140	1,380	0,236	2,217	0,035	0,345	0,059	0,554
26	0,75	0,162	1,413	0,272	2,376	0,040	0,353	0,068	0,594
77	0,8	0,172	1,430	0,290	2,460	0,043	0,357	0,072	0,615

3. Calculating Short Circuit Current

Below is the calculation of the short circuit current on bus 77

On bus 77

$$\begin{aligned}
 I_{3\text{fasa}} (\text{pu}) &= \frac{Ea}{Z_{1eq}} = \frac{1}{\sqrt{0,043^2 + 0,357^2}} \\
 &= \frac{1}{\sqrt{0,001 + 0,127}} \\
 &= \frac{1}{\sqrt{0,128}} \\
 &= 2,795 \text{ pu}
 \end{aligned}$$

$$\begin{aligned}
 &= \frac{0,14 \times 0,2}{\left(\frac{8068}{58,044}\right)^{0,02-1}} \\
 &= \frac{0,028}{1,103-1} \\
 &= \frac{0,028}{0,103} \\
 &= 0,271 \text{ s}
 \end{aligned}$$

$$\begin{aligned}
 I_{3\text{fasa}} (\text{A}) &= I_{3\text{fasa}} (\text{pu}) \times I_{\text{base}} \\
 &= 2,795 \times 2,8868 \text{ kA} \\
 &= 8,068 \text{ kA}
 \end{aligned}$$

By using the same method, the short circuit current value is obtained at each bus in the CD 12 feeder, as in the table below :

Table 3. 3-phase short circuit current calculation results

Bus	If ( A )	Tms (s)	Iset ( A )	K	A	TD ( S )
13	9266	0,2	58,044	0,14	0,02	0,264
15	9266	0,2	58,044	0,14	0,02	0,264
17	8331	0,2	58,044	0,14	0,02	0,269
26	8163	0,2	58,044	0,14	0,02	0,271
77	8068	0,2	58,044	0,14	0,02	0,271

The table above shows the calculation results for the short-circuit current on each CD 12 feeder bus. It can be seen that the magnitude of the short-circuit current is caused by the line impedance. The farther the fault location, the higher the impedance value and the lower the short-circuit current value. Conversely, the closer to the fault location, the lower the impedance value and the higher the short-circuit current value.

## 2. Calculation of Recloser Delay Time

In calculating the recloser delay time, the time setting value is seen from the time setting value. For a 20 kV feeder, the time setting value is :

$$\begin{aligned}
 \text{Load current} &= 55,28 \text{ A} \\
 I_{\text{set}} &= 1,05 \times I_{\text{beban}} \\
 &= 1,05 \times 55,28 \text{ A} \\
 &= 58,044 \text{ A}
 \end{aligned}$$

The time setting (Tms) can be determined by using the time and current curve formula :

$$Td = \frac{0,14 \times Tms}{\left(\frac{If}{Iset}\right)^{0,02-1}}$$

Where Td is the delay time set for the duration of the disconnection when there is a fault, the length of the delay time depends on the fault current, the higher/larger the fault current, the faster the disconnection time.

Time setting (Tms) on the bus 77

$$Td = \frac{0,14 \times Tms}{\left(\frac{If}{Iset}\right)^{0,02-1}}$$

By using the same method, the results of the recloser delay value are obtained at each impedance value in the CD 12 feeder, as shown in the following table:

Table 4. Recloser delay time calculation results

Bus	Jarak (km)	I <sub>3fasa</sub> (pu)	I <sub>3fasa</sub> (kA)
13	0,25	3,210	1,596
15	0,25	3,210	1,426
17	0,65	2,886	1,596
26	0,75	2,828	1,173
77	0,8	2,795	0,76

From the above, it is known that the magnitude of the short circuit current greatly influences the location where the fault occurs. When a short circuit current with a value of 9266 A occurs, the recloser delay time setting is 0.264 seconds. Meanwhile, when a short circuit current disturbance occurs with a value of 8068 A, the reclose delay time setting becomes longer, namely 0.271 seconds. So how fast or slow the recloser works is determined by the distance and the size of the short circuit current that is formed.

## 3. Short Circuit Analysis Using ETAP 16.0.0 Software

The short circuit analysis on the CD 12 feeder using ETAP 16.0.0 software aims to simplify the overall calculation. The simulation results of the short circuit current can be seen in the following table :

Table 5. Simulation results of 3-phase short circuit current using etap

Bus	Jarak(km)	I <sub>3fasa</sub> (pu)	I <sub>3fasa</sub> (kA)
13	0,25	3,210	9,266
15	0,25	3,210	9,266
17	0,65	2,886	8,331
26	0,75	2,828	8,163
77	0,8	2,795	8,068

From the table above, the short circuit current value at a distance of 0.25 km on bus 13 produces a current of 1.596 kA and at a distance of 0.8 km produces a current of 0.76 kA. So the further the location of the fault, the smaller/lower the short circuit current value.

## 4. Comparative Analysis of Calculation and Simulation

A comparative analysis was conducted to determine the differences between manual calculations and those using ETAP software. The results of the comparison can be seen in the table below :

Table 6. Manual calculation results of short circuit current

Bus	Jarak (km)	$I_{3\text{fasa}}$ (kA)
13	0,25	9,266
15	0,25	9,266
17	0,65	8,331
26	0,75	8,163
77	0,8	8,068

Table 7. Simulation results using ETAP software

Bus	Jarak (M)	$I_{3\text{fasa}}$ (kA)
13	0,25	1,596
15	0,25	1,426
17	0,65	1,596
26	0,75	1,173
77	0,8	0,76

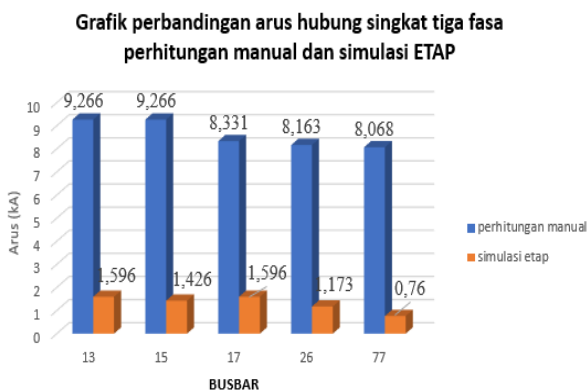

Fig. 2. Comparison chart of 3-phase short circuit current using manual calculation and

The graph above shows a difference between the manual calculation results and the simulation results using ETAP 16.0.0 software. The manual calculation results for bus 13 show a higher short-circuit current than the calculation using ETAP 16.0.0 software. The difference between the two is around 7,6 kA. The difference in results between the two is due to different calculation systems.

The manual calculation results show a higher short-circuit current value than the ETAP simulation. For example, the manual calculation yielded a current of 9.266 kA for bus 13, while the ETAP simulation only yielded 1.596 kA. This difference is primarily due to the manual method's simplified impedance calculations, while ETAP takes into account more comprehensive network parameter details.

These differences demonstrate that the use of simulation software can produce more realistic results that align closely with field conditions. This is crucial for protection coordination, as recloser settings based solely on manual

calculations are potentially less accurate than more detailed simulation results. Therefore, ETAP can serve as the primary reference for distribution protection settings, while manual calculations remain useful for initial validation.

#### IV. CONCLUSION

The closer the distance between the source and the short-circuit fault location, the greater the resulting short-circuit current. Conversely, the farther the fault location is from the source, the smaller the resulting short-circuit current. This indicates that distance significantly influences the magnitude of the fault current in an electric power system.

When a short-circuit fault with a current of 9266 A occurs, the recloser delay time is set to 0.264 seconds. However, when the fault current is smaller, namely 8068 A, the recloser delay time is actually longer, namely 0.271 seconds. This indicates that the smaller the fault current, the longer the recloser's operating time to open and close again tends to be.

Based on the comparison results between manual calculations and simulations using ETAP 16.0.0 software, it was obtained that the value of the three-phase short circuit current ( $I_{3\text{phase}}$ ) on bus 13 manually was 9.266 kA, while in the ETAP simulation it was obtained at 1.596 kA. Although there was a difference in value, in general the results of both did not show a significant difference in the trend of the protection system analysis.

#### REFERENCES

- [1] B. Krisna Juandika, B. Suprianto, And T. Rijanto, "Analisis Sistem Proteksi Hubung Singkat Pada Jaringan Tegangan Menengah 20kv Menggunakan Aplikasi Electrical Transient Analyzer Program (Etap) Di Pt. Pln (Persero) Ulp Ngunut."
- [2] A. Rahmatul Iklas And U. Situmeang, "Studi Penempatan Recloser Pada Jaring Distribusi 20 Kv Di Penyulang 12 Kualu Pt. Pln (Persero) Rayon Panam."
- [3] Jordan, Salahuddin, S. Meliala, And Kartika, "Analisis Penempatan Recloser Guna Memaksimalkan Kinerja Sistem Tenaga Listrik Di Jaringan Distribusi 20 Kv Pada Pt. Pln (Persero) Unit Pelaksana Pelayanan Pelanggan (Up3) Sigli," *Jurnal Energi Elektrik*, Vol. Volume 10, 2021.
- [4] H. Aulia Nanda, T. Murisal Asyadi, Dan Cut Daili, And P. Studi Teknik Elektro, "Analisis Kinerja Recloser Pada Penyulang Mk04 Dan Mk06 Di Ulp Meulaboh Kota," *Aceh Journal Of Electrical Engineering And Technology*, Vol. 3, 2023.
- [5] A. Fathia, D. Fariadi, And A. Bintoro, "Studi Recloser Untuk Memaksimalkan Kinerja Sistem Tenaga Listrik Pada Jaringan Distribusi Di Pt. Pln (Persero) Unit Layanan Pelanggan Beureunuen".
- [6] Yolnasdi, F. Palaha, And J. Efendi, "Perencanaan Penempatan Recloser Berdasarkan Gangguan Di Jaringan Distribusi 20 Kv Menggunakan Etap 12.6," Vol. Vol. 5, Dec. 2020.
- [7] T. Juniarto And M. T. Tamam, "Analisis Koordinasi Pengaman Over Current Relay, Ground Fault Relay, Dan Recloser Pada Penyulang Majenang 08 Pt. Pln (Persero) Gardu Induk Majenang Cilacap," 2019.

- [Online]. Available: [Http://jurnalnasional.ump.ac.id/index.php/jrre](http://jurnalnasional.ump.ac.id/index.php/jrre)
- [8] Y. Badruzzaman And A. Kusumawardani Politeknik Negeri Semarang, “Analisis Koordinasi Pmt, Recloser, Dan Sectionalizer Pada Sistem Proteksi Penyulang Sgn-02 Gi Sanggrahan Menggunakan Etap Berbasis Plc & Scada.”
- [9] W. Nursyifa Rumbaman, H. Purnama, J. Teknik Elektro, And P. Negeri Bandung, “Studi Koordinasi Proteksi Recloser Fuse Pada Jaringan Ieee 34 Node Menggunakan Etap,” 2021.
- [10] A. Tirtana, B. Hasan, And Y. Muladi, “Analisis Koordinasi Recloser Dan Pmt Penyulang Palasari (Plsi) Distribusi Jawa Barat Dan Banten Area Bandung.”
- [11] W. Kusuma, A. Hermawan, A. Nur Rahma, And M. Ilham Rifqi, “Analisis Perencanaan Pemasangan Recloser Pada Penyulang Untuk Meminimalisir Pemadaman,” *Elposys: Jurnal Sistem Kelistrikan*, Vol. 8, No. 3, 2021.
- [12] A. Sofwan And M. Fathur Rochman, “Analisa Sistem Koordinasi Kerja Relay Dengan Recloser Pada Penyulang Berbasis Simulasi Etap,” Dec. 2023.
- [13] A. Ghulomzoda *Et Al.*, “Recloser-Based Decentralized Control Of The Grid With Distributed Generation In The Lahsh District Of The Rasht Grid In Tajikistan, Central Asia,” *Energies (Basel)*, Vol. 13, No. 14, Jul. 2020, Doi: 10.3390/en13143673.
- [14] R. S. F. Ferraz, R. S. F. Ferraz, A. C. Rueda-Medina, And O. E. Batista, “Genetic Optimisation-Based Distributed Energy Resource Allocation And Recloser-Fuse Coordination,” *Iet Generation, Transmission And Distribution*, Vol. 14, No. 20, Pp. 4501–4508, Oct. 2020, Doi: 10.1049/iet-gtd.2020.0664.
- [15] M. Safari, M. R. Haghifam, And M. Zangiabadi, “A Hybrid Method For Recloser And Sectionalizer Placement In Distribution Networks Considering Protection Coordination, Fault Type And Equipment Malfunction,” *Iet Generation, Transmission And Distribution*, Vol. 15, No. 15, Pp. 2176–2190, Aug. 2021, Doi: 10.1049/gtd2.12164.
- [16] B. Ghosh, A. K. Chakraborty, And A. R. Bhowmik, “Reliability And Efficiency Enhancement Of A Radial Distribution System Through Value-Based Auto-Recloser Placement And Network Remodelling,” *Protection And Control Of Modern Power Systems*, Vol. 8, No. 1, Dec. 2023, Doi: 10.1186/S41601-022-00274-7.