

Design and Development of Automatic Fiber Optic Cable Roller using NodeMCU Esp 8266 Module

Widodo

Electrical Engineering, Faculty of Engineering, PGRI
Adi Buana University
Surabaya

Email: Widodo.adibuana@gmail.com

Nur Hidayat

Electrical Engineering, Faculty of Engineering, PGRI
Adi Buana University
Surabaya

Abstract—The process of winding fiber optic cable rolls takes a long time because it is done manually or conventionally. One of the tools in winding is a FO cable roller. This tool is designed to be able to roll fiber optic cables, but the limitations of this tool are still done manually, FO cables are rolled by hand like pedaling a bicycle on the pedals, the speed is set based on the speed of the rotation of the hand and it all

depends on the human factor. Therefore, there is a need for an Automatic Fiber Optic Cable Winder Using Node MCU ESP8266 and using Iot (Web of Things) to be more efficient and better in cable winding expositions.

Keywords: Automatic fiber optic cable winder, Node MCU ESP8266, internet of things (IoT)

I. INTRODUCTION

FO links are heavily used by various organizations that provide web association access and correspondence as a component of sending image views, such as messages, voice, and data. Communication using FO cable is this medium using light as a conduit of information or data. (Muharor et al., 2019). FO made of plastic & glass can send quickly. Fiber Optic Cable plays a very important role in this industry, especially in terms of sending access and is highly favored in the future.

Likewise, many local exercises or exercises are currently being carried out at home, so web access providers are increasingly needed, especially networks that utilize fiber optic links. To achieve a better, shorter and more secure process, in terms of security. One of the models is the advancement of control in electronic gadgets, in this way the makers need to make programmable fiber optic splice rollers or referred to as "modified fiber optic splice rollers" in order to help as many people as possible. will be considered normal during winding. fiber optic connection. The development of science and technology in the field of automation can lighten work and make work easier and more effective and more efficient. At this time we can not be separated from electronic devices, in this invention I designed an automatic roller using a motor.

One example of the technology that will be used in this tool is the internet, where the development is very significant. One example of the

technology that will be used in this tool is the internet, where the development is very significant, With change On this occasion, developments that can be controlled remotely via IoT affiliates are made to be more flexible.

II. METHODS

1.1 Product Design

As for the planning stages of the Design and Build of the Optical Fober Cable Automatic Roller Using the Node MCU ESP826 Module, the beginning of the design formation, obtained materials and manufacture as well as run - up of the tool. So that it can achieve maximum results, because the author's goal is to create this tool.

1.1.1 Arranging Instrument

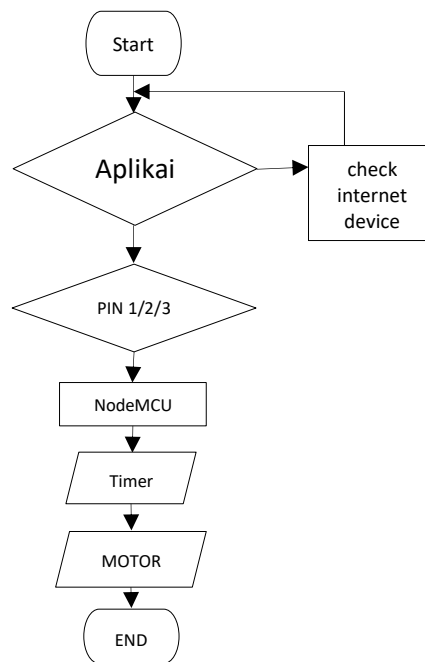
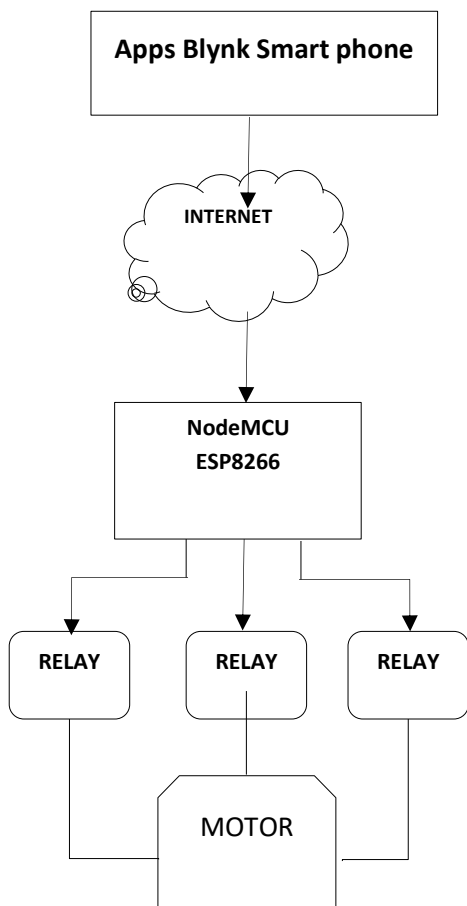

The formation of hardware includes the appearance of the form that is arranged as desired.

1.1.2 Framework Settings

This setting is the interaction recommended by the analyst.

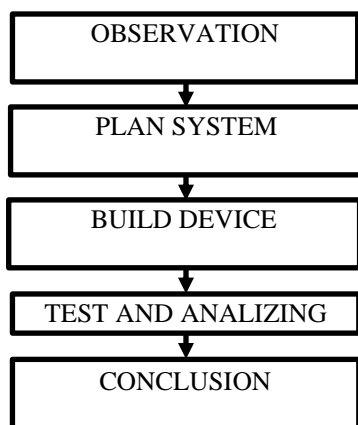

1.1.3 Automatic Fiber Optic Cable Winder Flowchart.

1.1.4 Tool Design Block Diagram

In this diagram, you can see a tool design block diagram with an explanation of the following sections

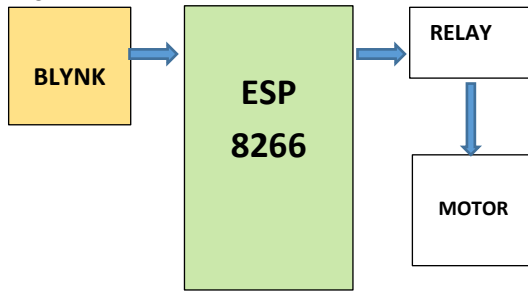

1.1.5 Drawing Desain

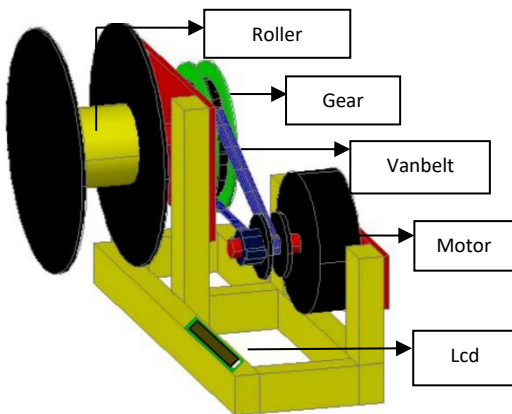

1.1.6 Instrument Framework

1. When Blynk works and gives an order to Node MCU, then, at that point, Node MCU identifies that order..
2. After that, Node MCU will give input or command to the relay after the program has been determined.
3. If the relay has detected a command, the motor will rotate and the roller will also rotate until it stops according to a predetermined program.
4. The motor work process is regulated by the Node MCU where the Node MCU has been programmed according to the work system described above.
5. Everything will work and then the LCD display will give a portrait display of the number of cable reels.

1.1.7 Wiring Diagram

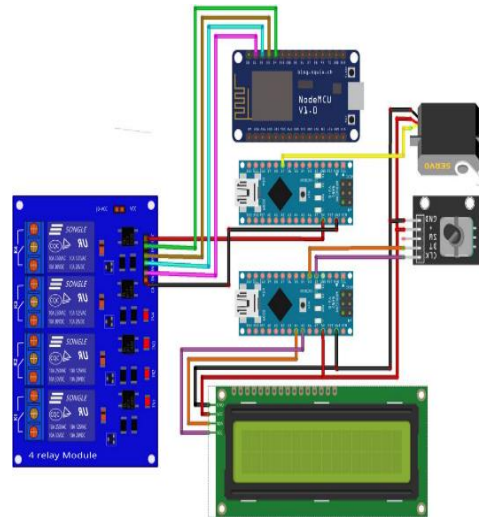

3.2 Product Test

In this product test, it will aim to display the results of the props functioning as expected or vice versa. If there is such a process, a review and process changes and a more detailed plan will be processed.

3.2.1 Rotary Encoder Test

In the design of this rotary encoder tool, it is used to change the rotary encoder's rotary motion into input for the microcontroller and is interpreted as a distance in m (meters).

3.2.2 Electric Component Test

- Individual tests are conducted to determine whether the components work normally and safely.
- Checked on the power supply, the input power supply was given a voltage of 220VAC, then measurements were taken using an avo meter on the result port, the estimated effect of the result port on the power supply was 5VDC, and that means the power supply is in good condition and ready to use.

3.2.3 Mechanical Component Test

- Manually rotate the gearbox to ensure that the gearbox rotation is not hard and can rotate without obstacles.

4. Presentation and Analysis

Here is an organizing system by sorting data into patterns, categories as well as important details so that topics can be found and work theory can be planned as suggested by the information.

4.1 Data Presentation

The collection and presentation of data is a very important part of making a report or research. Each type of report must involve information in introducing the current reality and data contained in the report (Dr. Bambang Widjanarko Otok, 2016). After getting the data, the data obtained can be displayed in 2 views, namely tables and diagrams. In the process of this research will be detailed the presentation of data from the system, namely testing the rotary encoder and testing the measurement of cable length and determining the error value..

4.2 Mechanical Design Result

The following is a design view of the automatic roller.

1. Control Circuit

This circuit is a combination of electrical circuits placed in a P 8266, 5 volt 4 channel relay, 16x2 . LCD



No	CIRCUIT	FUNCTION
1	Power supply	Voltage input source for all dc components.
2	Modul relay 5 volt 4 channel	AC motor controller
3	Lcd 16 X 2	As a portrait display the number of cable lengths
4	Arduino nano	Supporting data processing
5	Modul ESP 8266.	Recipient of data sent from blynk via the internet network

No	DEVICE	USING
1	AC Motor	AC motor for driving gearbox on cable winder
2	Servo Motor	Servo Motor Dc to move or level the cable position
3	Gearbox	Gearbox itself to connect power or engine power to one of the other parts
4	Chain	The chain is used as a link to read the rotation to the rotary encoder

4.3 Design Results on Blynk

The following is a display of the results of the initial input design of the fiber optic cable winder consisting of several initial views

1. Apps

This view is the blynk application which is displayed after the user opens the application and the user can press the button from several choices of the number of cables they want to roll according to the images and programs that have been set on the module..

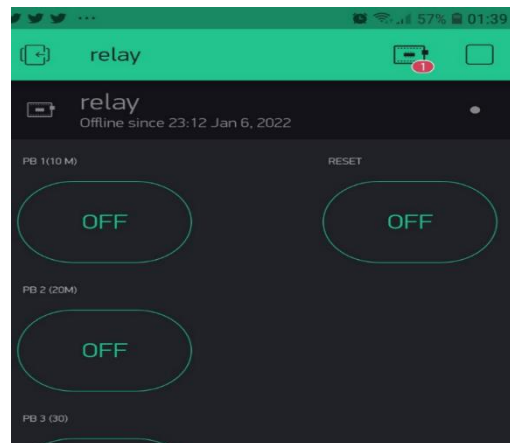

4.4 Test Results

Testing the tool serves to obtain whether the cable length measuring device is running as expected. The table below shows the test results getting a small error value.

The test experiment obtained the average of the tool and the calculation in this algorithm uses the following formulation:

$$\text{Distance} = ((2 \times \pi \times r) / N) \times \text{counter}$$

Description
 $\pi = 3,14$ (pi)

r = wheel spokes (10)

$(2 \times \pi \times r) =$ Circle formula

N = step one rotation of the rotary encoder (value in the program)

Counter = step by step rotary encoder

In the rotary encoder analysis, the value is 0.02 meters per step. And the value of one wheel rotation times displays 0.62 meters meters on the LCD.



The following are the results of the input cable lengths of 10 m, 20 m, 30 m with the analysis of the rotary encoder tool in several measurements. The tool was tested for 10 trials and then data was filled in the Lcd Display column and the coiled cable column.

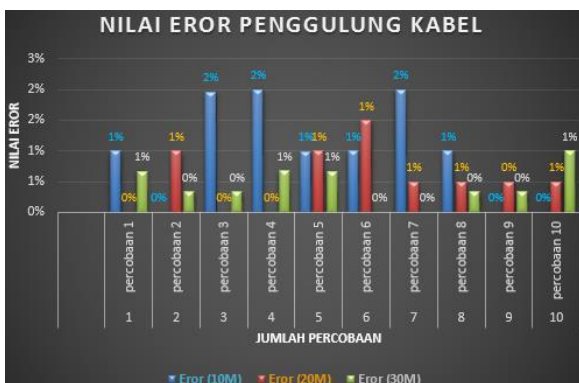

Axis X : Number of Trials.

Axis Y : Error Value.

Blue = Cable 10 m

Red = Cable 20 m

Green = Cable 30 m

In figure 4.5. Graph of measuring cable length and determining the error value. An error or problem was found in every rotary encoder experiment, this was due to sensor limitations.

NO	Test	Lcd Display (10m)	Lcd Display (20m)	Lcd Display (30m)	Cable (10m)	Cable (20m)	Cable (30m)
1	Test 1	10,1	20	29,8	10	20	30
2	Test 2	10	19,8	29,9	10	20	30
3	Test 3	10	20	29,9	10,2	20	30
4	Test 4	9,8	20	30	10	20	29,8
5	Test 5	10	19,8	29,8	10,1	20	30
6	Test 6	9,9	19,8	30	10	20,1	30
7	Test 7	9,8	19,9	30	10	20	30
8	Test 8	9,9	19,9	29,7	10	20	29,8
9	Test 9	10	20	29,9	10	20,1	29,8
10	Test 10	10	19,9	29,7	10	20	30

5. Conclusion and Suggestions

5.1 Conclusion

With the process of making the Design of Automatic Fiber Optic Cable Winder Using the ESP8266 NodeMCU Module, it can be concluded as follows.

1. The results of the design of this tool can operate properly.
2. The results of the design of this tool are made to facilitate and shorten the time of winding fiber optic cables more quickly and efficiently.
3. From the test results of this tool, the components used are in accordance with their respective functions and working systems. And be able to learn the working system of the tool correctly and correctly in accordance with the order of the design work system..

After going through several studies and a series of trials the design of this tool can operate according to its function.

5.2 Suggestions

There are various things that must be considered in the design or operation as well as in addition to maximizing the automatic roller again. Various tests that have been carried out from this research can be obtained several conclusions, namely as follows:

1. For the blynk application system, the appearance may need to be improved, and it can increase the display accuracy of the cable winding.
2. With this system, hopefully it can be one of the references for the next research.

6. REFERENCES

- Ahyar M1, Irdam2. Programmed Framework Plan for Electric Curl Winding Machine Based on Microcontroller Planning of Automatic Coil Winding Machine for Electric Motor Based on Microcontroller. Ambarita, J. (n.d.). Merencanakan dan Membuat Model Lokal yang Cerdik
- Web Of Things (IoT) Utilizing Blynk Application With ESP8266 Module.
- Arafat, S. Kom, M. Kom. (2016). Free Home Entrance (IoT) Security Framework With ESP8266. 7, 262-268.
- Dedy Prijatna, Muhammad Saukat dan Ahmad Thoriq.
- Design and Build of Automatic Gelasan Yarn Winding Machine in Kutamandiri Village, Tanjungsari District, Sumedang Regency.
- Dewi, N. H. L., Rohmah, M. F., & Zahara, S. (n.d.). Smart Home Prototype With Internet Of Things (IOT) Based NODEMCU ESP8266 Module. 9.
- Fitriyah, H., & Setyawan, G. E. (n.d.). Monitoring System Using Blynk and Controlling Mushroom Plant Watering With Fuzzy Logic Method. 8.
- Muharor, A., Asmara, B. P., & Bonok, Z. (2019). Analysis of Transmission of Fiber Optic Air Channels at 1310 nm Wavelength). Jambura Journal of Electrical and Electronics Engineering, 1(2), 49–54. <https://doi.org/10.37905/jjee.v1i2>.
- Rochman, Sagita, and Bagus Ilham Yunianto. "Prototype Automatic Lights Control System In The Mosque Area Based On Arduino Nano." *BEST: Journal of Applied Electrical, Science, & Technology* 1.1 (2019): 32-35.
- Rochman, Sagita, and Mochamad Taufiq Irvan Efendy. "Arduino Based Design of Horizontal Wind Power Generator for Coastal Road Lighting." *BEST: Journal of Applied Electrical, Science, & Technology* 3.1 (2021): 30-33.