

Design and Construction of Screw Type Micro Hydro Power Plant

Sagita Rochman

Department of Electrical Engineering
University of PGRI Adi Buana Surabaya
sagita@unipasby.ac.id

Muhammad Andy Hermawan

Department of Electrical Engineering
University of PGRI Adi Buana Surabaya
andypency1@gmail.com

The development of renewable energy is growing rapidly along with technological developments. One application of renewable energy is hydroelectric power (Water Turbine Generator). This study aims to design and manufacture a MHP using a permanent magnet generator with a screw type turbine and determine the output power generated from a MHP generator using a screw type turbine. In this research, an efficient and efficient MHP with screw type turbine will be developed. This research will be implemented in Dopleng Tretek, Prambon Subdistrict, Sidoarjo Regency. MHP is a power plant whose driving force comes from water flowing from the highlands to the lowlands. By utilizing the water discharge PLTMH can function to produce electricity which is driven through a turbine and rotates a generator. The main components of MHP are turbine, generator, and water discharge. If one of these components is not present, the MHP cannot function. By utilizing MHP we can enjoy electricity for free, the power generated by MHP is still small <0.5-100kW. From the design of the PLTMH generator using a screw type turbine the output voltage is 9 volts with a water flow of 557 m³/s. The greater the flow of water flowing in the cross section of the turbine, the faster the resulting rpm.

Keywords: MHP, Turbine, Generator, Water Discharge.

I. INTRODUCTION

The development of renewable energy is growing rapidly along with technological developments. One application of renewable energy is hydroelectric power (Water Turbine Generator). This is because flowing water has a flow rate that can produce kinetic energy that has torque, so that it can be used as electrical energy.

The greater the flow of water, the greater the torque produced, especially at the Micro Hydro Power Plant (PLTMH).

The development of PLTMH in current conditions is increasingly rapid, in its development the PLTMH is currently portable with construction floating on the surface of the water utilizing kinetic energy as a source of turbine propulsion energy, it can be used at any time without large construction construction (Sihaloho, 2017). This can be implemented in an environment that has potential.

In previous studies, a screw turbine design has been obtained which is effective at the blade angle and turbine head conditions (I Putu Wahyu Indra Wedanta, 2021). In this research, an efficient and efficient MHP with screw type turbine will be developed.

This research will be implemented in Dopleng Tretek Hamlet RT: 03, RW: 02 Prambon Subdistrict, Sidoarjo Regency.

II. METHODS

Tool planning will begin in July 2021, starting from the design design, material acquisition and manufacture as well as the run-up of teaching aids. So that maximum results can be obtained and do not disappoint, because it also remembers the intent and purpose of the author in making this teaching aid

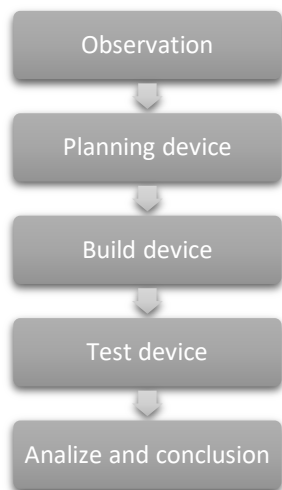

Figure. 1 Research Block Diagram

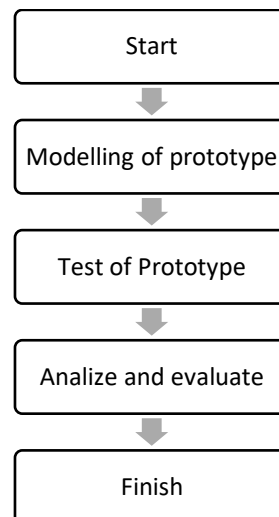

Figure. 3 Flow chart

The following is a test block diagram of the micro hydro power plant modeling and data recording that will be carried out.

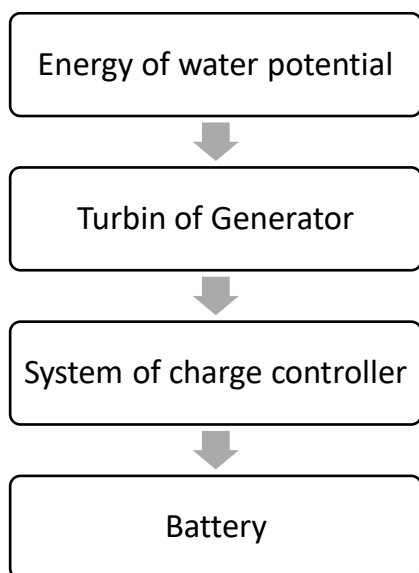

Figure. 2 Block Diagram System planning

The workings of the micro hydro power generation system are the discharge of the water channel, turning the screw on the generator, which produces electrical energy. The output of the generator is rectified through a rectifier diode. Then the power will enter the buck boost converter to charge the battery.

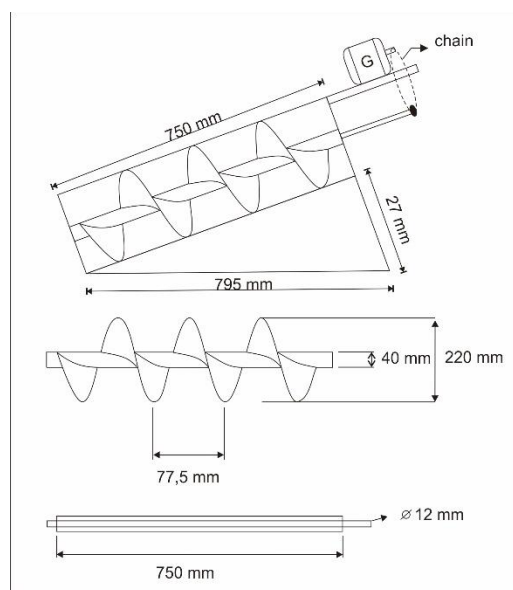

Figure. 4 Product design

III. RESULT AND DISCUSSION

In this design research, it produces a product that functions as a screw type Micro Hydro Power Plant Serves as a micro-scale power plant. The potential power of water is converted into mechanical energy through a screw turbine, the turbine rotation results are coupled to an electric generator. The electrical power generated by the generator will be stored in a 12 V DC battery. From this battery it can be used for the desired needs. In the application that we use, it can be converted into an AC voltage of 220 V by using an inverter.

Here is a picture of the product results:



Figure. 5 Power circuit result

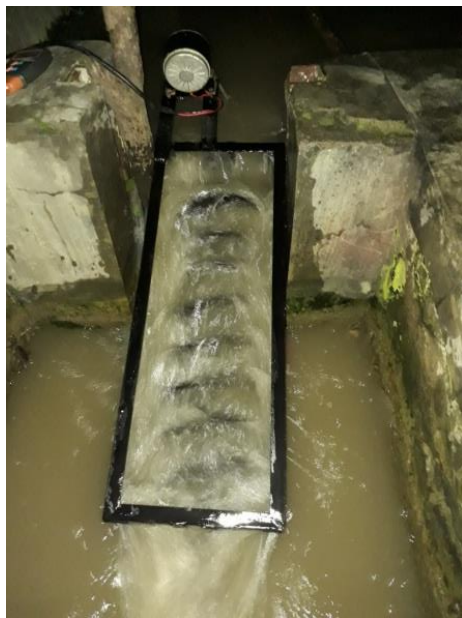

Figure. 6 Turbine screw yield

3.1. Water Deposit Measurement

This test is carried out to determine the potential for available water discharge in irrigation canals. This water discharge is used as a driving force for a screw turbine which will be coupled to an electric generator. The greater the flow of water, the better the turbine rotation produced. The cross-sectional area can be known from the width of the river surface and its height.

$$Q = A \cdot v$$

$$A = t \cdot l$$

Where:

$$Q = \text{Fluid flow discharge } \left(\frac{m^3}{s}\right)$$

$$A = \text{Cross – sectional area } (m^2)$$

$$v = \text{Flow speed } \left(\frac{m}{s}\right)$$

$$t = \text{Tall } (m)$$

$$l = \text{Wide } (m)$$

From the results of measurements in the field obtained:

Table 1. Water discharge data

NO	Tall (m)	Wide(m)	A (m ²)	v (m/s)	Q (m ³ /s)
1	40	105	4200	0,1	420
2	41	105	4305	0,1	430,5
3	43	105	4515	0,1	451,5
4	45	105	4725	0,1	472,5
5	47	105	4935	0,1	493,5
6	48	105	5040	0,1	504
7	50	105	5250	0,1	525
8	52	105	5460	0,1	546
9	53	105	5565	0,1	556,5
10	55	105	5775	0,1	577,5

3.2. Screw Turbine Rotation Test

In the turbine rotation test, it is carried out to determine the thrust generated by the water discharge against the rotating power of the screw turbine.

Table 2 Data on the flow rate of the screw turbine rotation and generator rotation output.

No	Water discharge (m ³ /s)	Screw Turbine Rotation (rpm)	Voltage (V)
1	420	120	3,7
2	430,5	123	3,8
3	451,5	129	3,9
4	472,5	135	4,1
5	493,5	268,5	8,1
6	504	274	8,3
7	525	285,5	8,6
8	546	297	9,02
9	556,5	292	8,8
10	577,5	303	9,2

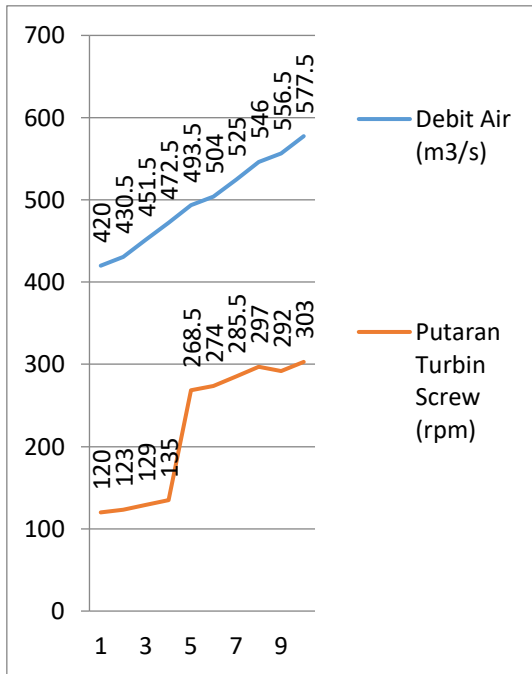

Figure. 7 Turbine rotation diagram of electric current

3.3. Electrical Generator Output Voltage Test

The generator used in this design is a permanent magnet DC generator. Where the generator has an output that is limited to the magnitude of the magnetic value of the magnet itself. The voltage generated from the generator comes from the magnetic flux that passes through the generator coil, the voltage is connected through the commutator ring using a carbon brush. From table 2, the line diagram can be obtained as follows:

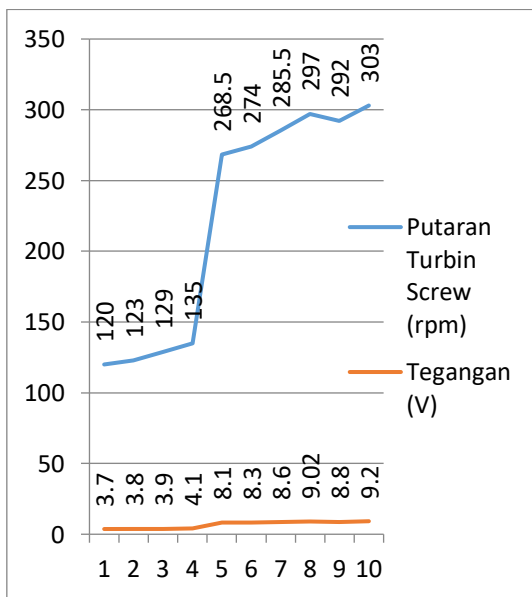

Figure. 8 Diagram of turbine rotation against voltage

3.4. Testing the Current Produced by the Generator

This test is to determine the current output that can be generated by the generator. The tool used to measure electric current is an ampere meter, to use it it can be connected in series with the generator output.

Table 3 Turbine rotation on electric current

No	Screw Turbine Rotation (rpm)	Current (mA)
1	120	13
2	123	12,91
3	129	12,95
4	135	13
5	268,5	12,98
6	274	13,02
7	285,5	13,03
8	297	13,06
9	292	13,08
10	303	13,13

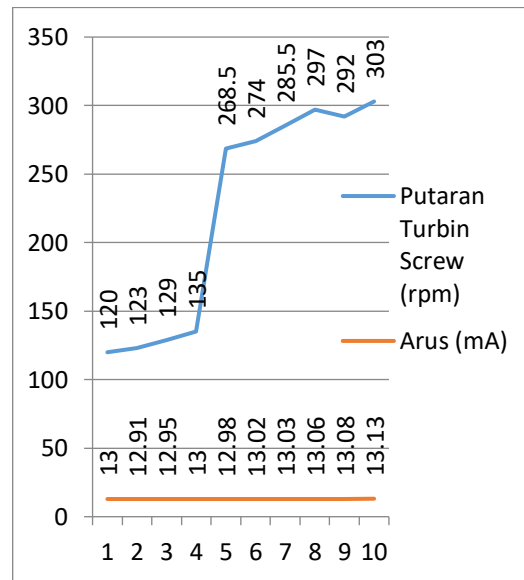

Figure . 9 Diagram of turbine rotation against electric current

3.5. Electric Generator Power Test

Testing on this tool is carried out to determine the electrical power produced by the MHP that has been made. The screw turbine will be given a water discharge so that it can rotate an electric generator, from the generator an electrical power output will be obtained.

Table 4 Electrical Generator Power Test

No	Debit of water (m ³ /s)	Rotation Screw (rpm)	Voltage (V)	Ampere (mA)	Power (Watt)
1	420	120	3,7	13	0,0481
2	430,5	123	3,8	12,91	0,049
3	451,5	129	3,9	12,95	0,05
4	472,5	135	4,1	13	0,05
5	493,5	268,5	8,1	12,98	0,1
6	504	274	8,3	13,02	0,1
7	525	285,5	8,6	13,03	0,11
8	546	297	9,02	13,06	0,11
9	556,5	292	8,8	13,08	0,11
10	577,5	303	9,2	13,13	0,12

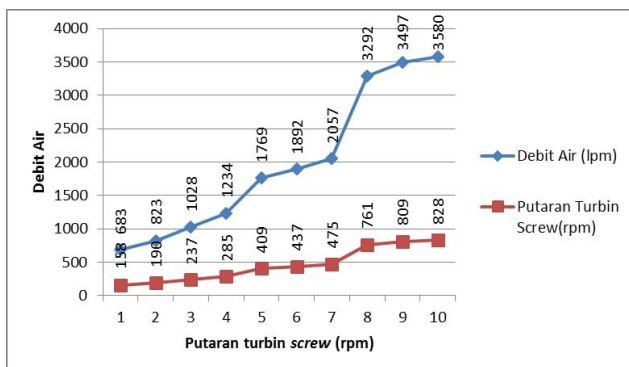
**Figure. 10** Diagram of water discharge against electric power

IV. CONCLUSIONS

Research that has been carried out in the design of micro hydro power plants with screw type torque produced from screw turbines depends on the cross-sectional area, the larger the cross-sectional area, the greater the torque generated. From the research obtained in the field, this research can be concluded as follows:

1. From the design of the PLTMH generator using a screw type turbine, the output voltage is 9 volts with a water flow of 557 m³/s.
2. The greater the flow of water flowing in the cross section of the turbine, the faster the resulting rpm.

REFERENCES

- [1] Arismunandar.,S. Kuwahara. 2000. Electrical Power Engineering volume I. Jakarta: PT. Pradnya Paramita.
- [2] Bakri, Fauzi and hadiyanto, Roy. 2013. "Design of a Portable Micro Hydro Prototype Using Cross Flow Turbine". Journal of Physics Research. Thing. 19-25.
- [3] D. L. Sihaloho. 2017. "Design of a Model Test Equipment for a Micro Hydro Power Generation System (MHPP) Using a Cross-Flow Turbine".
- [4] Ma'ali Nasrul. 2017. "Planning for the Kepung Micro Hydro Power Plant (PLTMH) in Kediri Regency".
- [5] Nasir, Bilal Abdullah. 2013. "Desing of Micro – Hydro – Electric Power Station", International Journal of Engineering and Advanced Technology (IJEAT) ISSN: 2249 – 8958, Volume-2, Issue-5.
- [6] Nugroho, Hunggul Y.S.H & Sallata, M. Kudeng. 2015. "Micro Hydro Power Plant (MHP)". Andi Offset
- [7] Rochman, Sagita. "Design Of Vertical Axis Savonius Windmill for Generating Electricity Using Permanent Magnet." *Tibuana:: Journal of Applied Industrial Engineering* 3.01 (2020): 61-66.
- [8] Rochman, Sagita, and Bagus Ilham Yuniarto. "Prototype Automatic Lights Control System In The Mosque Area Based On Arduino Nano." *BEST: Journal of Applied Electrical, Science, & Technology* 1.1 (2019): 32-35.
- [9] Saefudin, Encu, et al. 2017. "Screw Turbine for Eco-Friendly Micro-Hydro Scale Power Plant".
- [10] Soemarto, C.D. 1995. Hydrology for Irrigation. Jakarta: PT. Pertja.
- [11] Suwito, et al. 2017. "Battery Charging System in Solar Energy System with Buck Boost Converter for Various Lighting Levels at Airports".
- [12] Wedanata, I Putu Wahyu Indra. 2021. "Analysis of the Influence of Head Tilt and Variation in the Angle of the Threaded Turbine Blade on the Performance of MHP".
- [13] Widayaka, Yohanes Eka Arif. 2011. "Microhydro Power Plant Using Pelton Turbine with Number of Blades 16 and 18".
- [14] Widodo, Muh.Hasan Ashari. 2011. Modification of Existing Stator. Center for Electric Power and Mechatronic Research, LIPI.

