

# Implementation of The Internet of Things for Public Street Light

**Atmiasri**

Department of Electrical Engineering  
University of PGRI Adi Buana  
Surabaya, Indonesia  
atmi.asri@unipasby.ac.id

**Moh. Andika Pratama Putra**

Department of Electrical Engineering  
University of PGRI Adi Buana  
Surabaya, Indonesia  
moh.andika31@gmail.com

**Abstract**—Currently, there are still many street lighting systems with electrical resources that use a full power system or a time system to regulate the power issued by the lamp so that in terms of the costs incurred for the lamp, it is also quite large. And in terms of maintenance, for now the problematic street lighting is still using conventional methods, namely waiting for damage reports from the field directly so that the handling of damaged lamps is very slow. Based on these problems, a street lighting lamp with automatic control will be designed that can adjust the light intensity and report the status of the lamp online through the Internet of Things (IoT) website which can be accessed using a smartphone or PC connected to the internet so that energy use and handling actions will be carried out. damage is more efficient. In this study, an automatic PJU was designed with a Passive Infrared Receiver (PIR) sensor to detect the presence or absence of objects around the lamp and an ESP module to connect the hardware to the internet network via a Wi-Fi connection. For the automatic system of turning on and off the lights based on bright and dark conditions of sunlight using a Photocell containing a Light Dependent Resistor (LDR). With the use of this system, it can be proven that the use of Passive Infrared Receiver (PIR) sensors and Thingspeak website-based monitoring can streamline spending on electricity financing and accelerate the handling of lamp damage.

**Keywords**— *Street Light, monitoring, Thingspeak, IoT*

## I. INTRODUCTION

In general, Penerangan Jalan Umum (PJU) or street light is a lamp that is used to illuminate the road at night in order to increase comfort in traffic and safety for road users. Street lighting used still use electricity because maintenance and purchase costs are much cheaper and easier than solar lamps. In addition to problems with energy consumption, lamp damage often occurs which is not immediately repaired by the local person in charge due to delays in receiving information on damage to street lamps. [1]

Seeing these problems, street lamps are needed that can regulate power consumption and send the status of damage to street lamps quickly to the person in charge of street lamp maintenance so that the safety and comfort of road users is maintained. [2]

PJU lamps are LEDs arranged in such a way with a lens as a reflector so that they can produce very bright light with a high lux value with much lower power . With the use of LED lights, power settings can be

adjusted as desired easily, the lamp power used is usually from 20watt to 200watt. PJU lamps are LEDs arranged in such a way with a lens as a reflector so that they can produce very bright light with a high lux value with much lower power . With the use of LED lights, power settings can be adjusted as desired easily, the lamp power used is usually from 20watt to 200watt. [3]

This PIR Sensor module allows to detect human movement at a certain distance . The sensor with this small size is very easy to use. Output LOW if motion is detected and output HIGH if not detected. The PIR Sensor HC-SR501 has two potentiometers that function as delay timers and sensitivity settings. This sensor requires a voltage source of 5Volt DC to operate. Module ESP8266 is A very inexpensive but really effective platform to use to communicate or control over the internet either used alone or by using an additional microcontroller in this case the Arduino as the controller. [4] [5]

ACS712 or Hall Effect current sensor is a module that functions to detect the flow of electric current through it. This sensor has a reading with high accuracy, because it contains a low-offset linear Hall circuit with a single pass made of copper. [6] The way this sensor works is that the current that is read flows through the copper cable contained in it which produces a magnetic field that is captured by the IC and converted into a proportional voltage. Thingspeak.com is a server dedicated to the Internet of Things Device, free of charge that can be used to create IoT projects, and can be accessed anywhere. [7]

## II. METHOD

### A. Research design

Hardware and software are 2 parts of this system design. Arduino uno microcontroller, PIR sensor, LDR (Light Dependent Resistor), current sensor, voltage sensor, LED light and wifi module are part of the hardware. For software using C language on the microcontroller, especially for the Arduino IDE editor, while for GUI monitoring via the website using the monitoring feature from the ThingSpeak.com website.

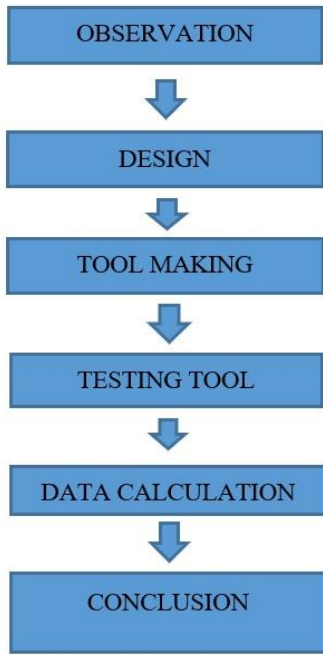

Figure 1. Research block diagram

B. Hardware Design

The hardware is designed to consist of several devices according to the block diagram.

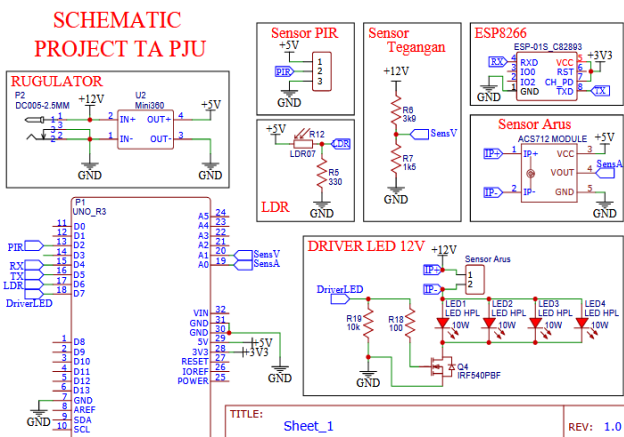

Figure 2. Schematic Design

C. GUI (General User Interface)

In this study, to monitor the value of voltage, current and power, an interface in the form of a website will be used which will later store and display the data sent by the hardware. Apart from the website, it can also be accessed via an application on a smartphone. In this study, a 3rd party application, namely Thingshow, was used which retrieves data from Thingspeak by entering the channel ID from the field created in Thingspeak.

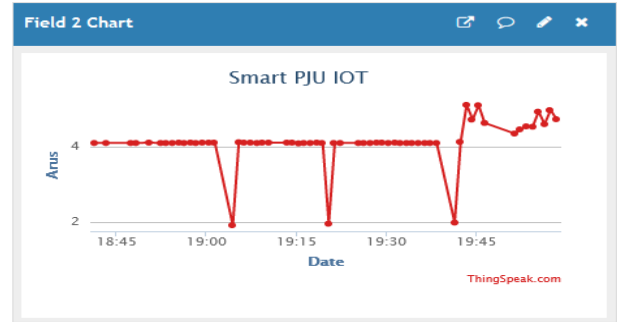

Figure 3. User interface display

III. RESULT AND DISCUSSION

A. PIR Sensor Testing

In this study, the PIR sensor is used as a determinant of how the LED light works when it detects or does not detect objects. The test was conducted to determine the sensitivity of the PIR sensor used in PJU lamps. The following is a description and data collection.

1. PIR Sensor Data Analysis

Testing of the PIR sensor is carried out by activating the PJU electronic circuit and then conditioning the photocell to be in a night or dark position by closing the LDR surface. When the circuit is active, the test is carried out by moving the hand in front of the PIR sensor, if the PIR sensor detects an object it will be marked with a brightly lit PJU lamp and maximum power. If the object is not detected it will light up dimly. This experiment was carried out 10 times to ensure the sensor worked properly. Sensor data retrieval is only based on 2 conditions, namely YES which means it is functioning properly and NO which means the sensor is not working properly.

2. PIR Sensor Data Discussion

Of the 10 existing data shows a situation where 8 trials were successful and 2 trials failed. The sensitivity factor and the distance from the sensor greatly affect the flame conditions of the lamp. When there is a failure in sensor detection, it can be said that the sensor has a sensitivity problem. With a problem like this, the object detection program on Arduino is engineered so that the sensor is declared to actually detect the object if there are 2 times the detected object movement in a short time.

Table 1. Sensor Response

Trial to	Sensor Response
1	YES
2	YES
3	NO
4	YES
5	YES
6	YES

7	NO
8	YES
9	YES
10	YES

**B. Photocell Test**

In this study, the photocell sensor is used as a determinant of how the LED lights work when detecting night and day. Tests were carried out to determine the sensitivity of the photocell sensor used in PJU lamps. The following is a description of data collection and discussion.

**1. Photocell Data Analysis**

Testing of the photocell sensor is done by activating the PJU electronic circuit. When the circuit is active, the test is carried out by alternately closing and opening the LDR surface, when closed indicates night conditions and when opened indicates conditions are in the daytime. If the photocell sensor is in a dark condition, the light will turn on at low power, and if the photocell is in a bright condition, the light will not be allowed to turn on. Based on these conditions, it is determined whether the photocell is functioning properly or not. This experiment was carried out 10 times to ensure the sensor worked properly. Sensor data retrieval is only based on 2 conditions, namely YES which means it is functioning properly and NO which means the sensor is not working properly.

Table. 2 Photocell Sensor Respons

Trial to	Condition	Sensor Response
1	Bright	YES
2	Dark	YES
3	Bright	YES
4	Dark	YES
5	Bright	YES
6	Dark	YES
7	Bright	YES
8	Dark	YES
9	Bright	YES
10	Dark	YES

**2. Discussion of Photocell data**

From all available data, it shows that the determination of dark and light decisions from the LDR on the Arduino program goes well. The analog voltage value received by the Arduino analog input and converted to a decimal value is limited to a value of 20 decimal places, when the value is < 20 it is considered night and when the value is > 20 it is considered bright. Of the 10 experiments carried out under conditions of 5 day or light data and 5 night or dark data, photocells gave a good reaction.

**C. Testing Current Sensor**

In this study, the current sensor is used as a device whose job is to read the amount of current from the PJU lamp. The test is carried out to determine the level of accuracy of current readings from the load in the form of PJU lamps. The following is a description of

data collection and discussion.

**1. Data Analysis of Current Sensor**

Testing of the current sensor is done by activating the pju electronic circuit. When the circuit is active, the test is carried out by turning on the PJU lamp with a varying current value, this is done by changing the PWM value of the LED driver, the reading results are directly seen on the serial terminal of the Arduino. In addition, at the input of the LED power source, an ampere meter is also installed in series which functions as a comparison for the acs current sensor readings. The number of variations in the value of the load is given from a small load to a maximum load to then calculate the error rate from the sensor reading, this is very important for the next stage of measurement. The magnitude of the error value from sensor readings is recorded in percentage units.

Table. 3 Current Sensor Respons

No.	Data ACS (A)	Data of Multimeter (A)	% Error
1	0.3	0.31	3.33
2	0.5	0.54	8
3	0.8	0.86	7.5
4	1	1.08	8
5	1.3	1.2	7
6	1.8	1.8	0
7	2.1	2.2	4.7
8	2.5	2.54	1.6
9	2.7	2.7	0
10	3.1	3.15	1.6

**2. Discussion Data Current Sensor**

It can be seen from the results of the current sensor data collection, the minimum error percentage value shows a very accurate value, namely 0% or there is no error from the acs current sensor reading. Meanwhile, the largest error value in this experiment is 8%. If on average, the percentage error of the acs current sensor reading is 4.17%. The range of values for the magnitude of the error, starting from no error, to producing an error of 8%, is a fairly wide range of values. This happens because of the nature of the acs which detects the amount of current from the hall effect process which causes a lot of ripple waves that cause the analog voltage output from the acs sensor to also have ripples so that the sensor readings also fluctuate randomly and quickly. To minimize this, the output of the current sensor readings is stored several times and the average value is taken and then the data is sent.

**IV. CONCLUSION**

From the tests that have been carried out, the results of this study can be concluded that:

- a. The use of the PIR sensor as a source for detecting objects that pass through the PJU lights is quite

effective, but only for objects in the form of humans

- b. The sensor output value, which is an analog voltage, still has a ripple signal so that the readings on the microcontroller are unstable.
- c. A power saving system using object movement references is good enough
- d. This system produces an accuracy rate of about 96.7% so that the power saving system using object movement references is quite good

#### REFERENCES

- [1] Elang Pratama (2017), "Power Efficiency of Public Street Lighting", UNNES.
- [2] Khalil, H., Abas, N. and Rauf, S. (2017), Intelligent street light system in context of smart grid, 2017 8th International Conference on Computing, Communication and Networking Technologies (ICCCNT).
- [3] Mansur (2015), "Electrical Analysis of PJU Lights for office areas konawe", Halu Oleo University.
- [4] Norazizi and Adam (2019), "SMS-based Public Street Lighting Monitoring System," J. Ilm. Flash , vol. 5, no. 1, pp. 23–28.
- [5] Putri Sundari, Niar Suwiarti S, et al. , (2017), Proposal for Solar Street Lighting Installation (PJUTS) Probolinggo-Banyuwangi Toll Road .
- [6] PVA Wibawa, OS Komang, and AAN Amrita (2019), "Design and Build a Web-Based Street Lighting Monitoring System," J. Spektrum, vol. 6, no. 4, pp. 51–57.
- [7] Rochman, Sagita, and Bagus Ilham Yuniarto. "Prototype Automatic Lights Control System In The Mosque Area Based On Arduino Nano." *BEST: Journal of Applied Electrical, Science, & Technology* 1.1 (2019): 32-35.
- [8] Rochman, Sagita, and Mochamad Taufiq Irvan Efendy. "Arduino Based Design of Horizontal Wind Power Generator for Coastal Road Lighting." *BEST: Journal of Applied Electrical, Science, & Technology* 3.1 (2021): 30-33.
- [9] Yaumul Ihsan (2015), "Design of a PJU-based light control system" atmega328", UIN Maulana Malik Ibrahim Malang.