

Designing A Surveillance System, Temperature and Humidity Detection Based on Internet of Things (IoT) In The Server Room University Of PGRI Adi Buana Surabaya

Dwi Hastuti

Department of Electrical Engineering
University of PGRI Adi Buana Surabaya
dwi.hastuti@unipasby.ac.id

Anggarda Saputra Wijaya

Department of Electrical Engineering
University of PGRI Adi Buana Surabaya
Anggarda.wijaya@outlook.com

Abstract—University of PGRI Adi Buana Surabaya is a university located in Surabaya, East Java. All data management processes and academic information systems are connected to the server via a local network and the internet. Currently there are three server rooms owned by the University, namely: the main Server room in the PGSD Building, second floor; Backup Server room in the Postgraduate building, third floor; and network Server room in the Ngagel campus, building a, second floor. The server room accommodates network equipment and database servers require temperature and humidity that are always maintained and routinely need to be checked by officers. To avoid damage to the server and network devices in the server room, a temperature and humidity detection system based on the Internet of Things (IoT) is made. This system is built using Home Assistant as an application of Internet of Things (IoT) centralized control system and CCTV to display conditions in real-time in each server room. Sensor to detect temperature and humidity using the DHT11 Sensor, the ESP8266 Microcontroller acts as a link between the host and the sensor by utilizing a wireless network. This tool can provide benefits in the field of Information Technology and Data in terms of monitoring so that it officers can check anytime and anywhere through a Web Service.

Keywords—Server room, Internet of Things (IoT), CCTV, DHT11 sensors

I. INTRODUCTION

Server room is a room used to store database servers, network devices and other devices where these devices are very vital and need supervision and always maintained temperature and humidity. Server room is one of the important assets in Pgrri Adi Buana University Surabaya. Currently there are three server rooms owned by the University, namely: the main Server room in PGSD Building, second floor; Backup Server room in postgraduate building, third floor; and network Server room in Ngagel campus, building a, second floor. During this time officers routinely check into the server room at the three locations. This makes the process time consuming, expensive, and also laborious.

To avoid damage to server and network devices and supervision that can continue to be carried out in the server room, a monitoring system, temperature and humidity detector based on the Internet of Things (IoT) is made. Some studies that are relevant to this are remote temperature monitoring systems in server rooms based on the Internet of Things (IoT). The study used the ESP8266 Microcontroller with the main sensor DHT11 sensor. This

system is designed and developed to monitor temperature both through the Thingspeak Website and the Virtuino Android application (Fatra, et al, 2021). From a journal written by (Yunarti, Baharuddin, 2017) entitled Designing a temperature measuring system in a server room using Raspberry Pi and DHT11 temperature sensor is a study about designing a temperature measuring system in a server room using Raspberry Pi and DHT11 temperature sensor that takes temperature samples by Stratified Random Sampling.

The system is built using Home Assistant as a centralized control system application Internet of Things (IoT), where the host is integrated into the infrastructure of the University and CCTV to display the conditions in real-time each server room. Sensor to detect temperature and humidity using DHT11 Sensor, ESP8266 Microcontroller acts as a link between Host and Sensor by utilizing wireless network. This tool can provide benefits in the field of Information and Data Technology in terms of monitoring temperature, humidity, and conditions in three server rooms so that it officers can check anytime and anywhere through a Web Service.

II. METHODS

A. Product Design

Researchers strive to create an innovative tool to facilitate the monitoring, detection of temperature and humidity-based Internet of Things (IoT) at the University of PGRI Adi Buana Surabaya. The following is a flowchart and explanation of the working system of the designed tool.

1). Block Diagram

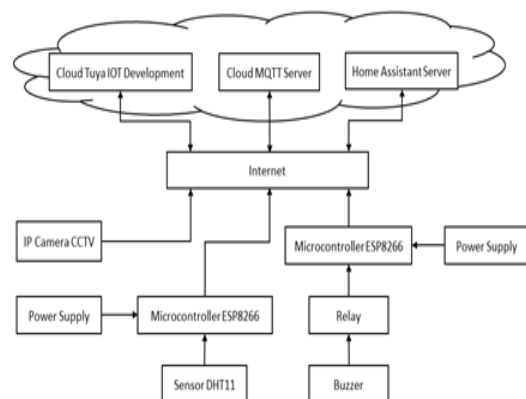

Fig 1 Block Diagram

From the block diagram above a little about the description of the object of this study and the following explanation of the function of each block diagram:

1. Microcontroller ESP8266

The ESP8266 Microcontroller receives data from the DHT11 sensor, transmits data over the internet network using the MQTT protocol.

2. DHT11 Sensor

The DHT11 Sensor is used to detect temperature and humidity in the server room.

3. Buzzer

Buzzer is used for certain indications or warnings that there is a decrease and increase in temperature and humidity in the server room.

4. IP Camera CCTV

IP camera CCTV is used to supervise, monitor or record conditions in three server rooms of PGRI Adi Buana University Surabaya.

5. Internet

Internet is used for connecting ESP8266 microcontroller with MQTT cloud through MQTT protocol and IP Camera with cloud through HTTP protocol.

6. Cloud Tuya

Tuya Cloud serves as a backend system to authorize CCTV IP Camera users to be accessed remotely.

7. Cloud MQTT

The MQTT Cloud serves as the backend system for authorizing and authenticating MQTT users.

8. Homeassistant

Home Assistant serves as a monitoring application which is one part of the Internet of Things (IoT) technology as the data center of this study.

2). Design of Product

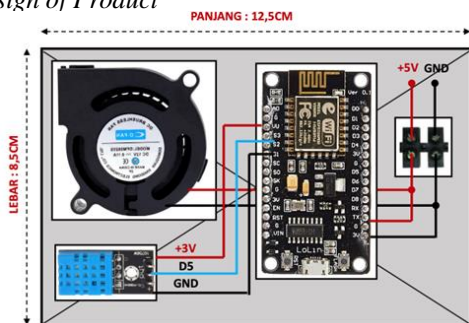

Fig 2 Design of Temperature and Humidity Detection

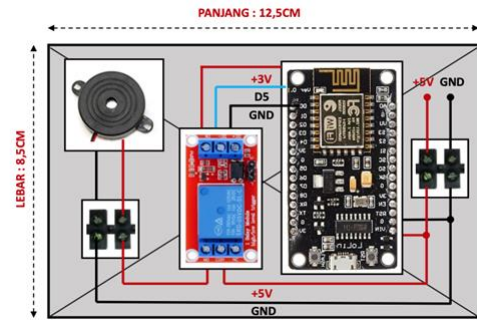

Fig 3 Design of Alarm

3). Wiring Diagram Prototype

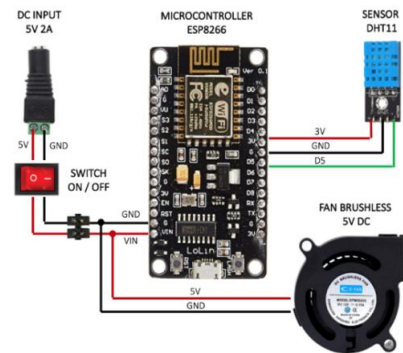

Fig 4 Wiring Diagram of Temperature and Humidity Detection

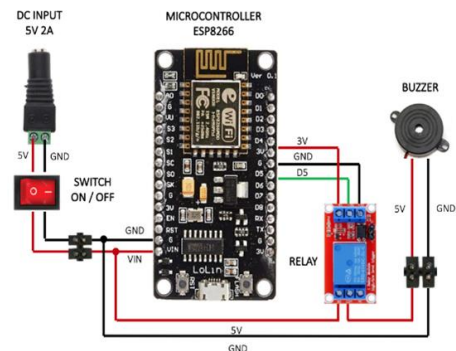

Fig 5 Wiring Diagram of Alarm

4). Display of Home Assistant

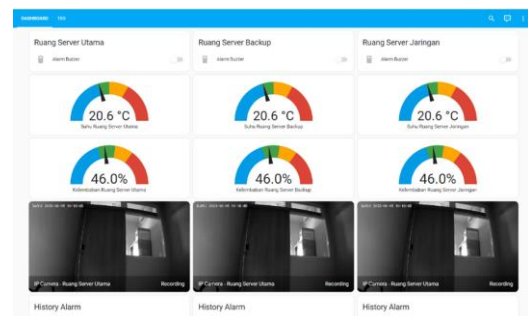

Fig 6 Display of Web Monitoring Home Assistant

5). System Workflow

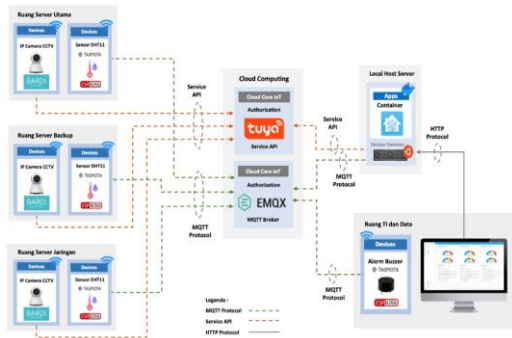

Fig 7 System-Wide Workflow

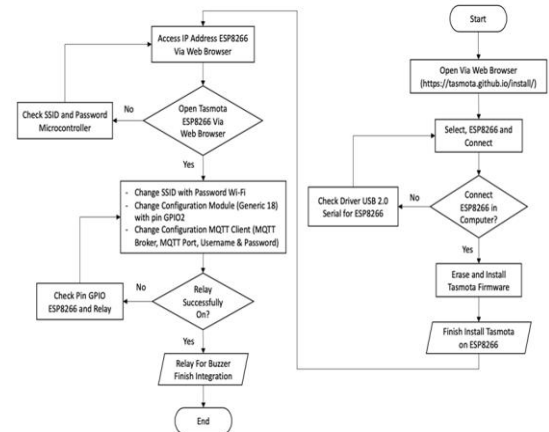

Fig 11 Flowchart install and configure Tasmota in microcontroller ESP8266 integrated with Relay for Buzzer

6). Flowchart

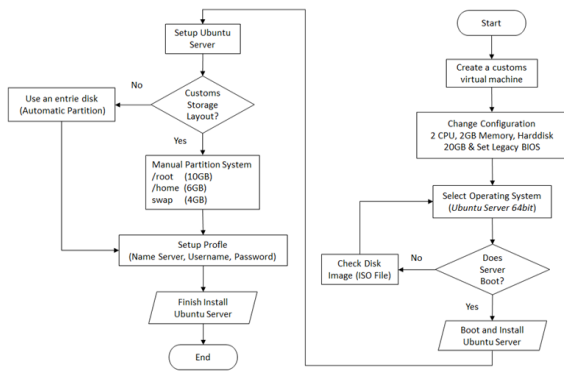

Fig 8 Ubuntu Server 22.04 LTS installation and configuration Flowchart on VMware

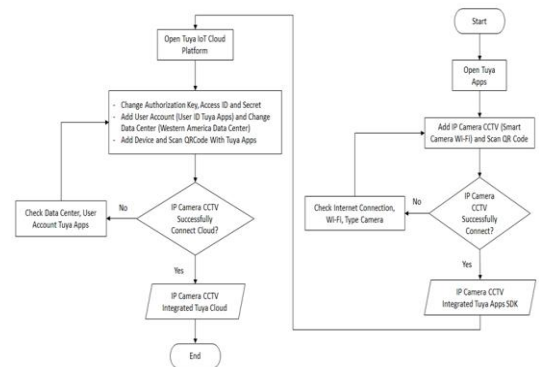

Fig 12 Flowchart install and configure Tasmota in microcontroller ESP8266 integrated with Relay For Buzzer

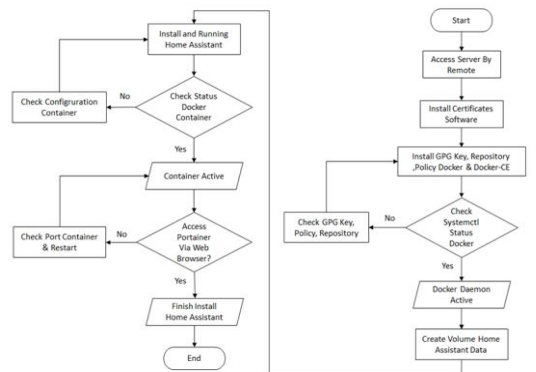

Fig 9 Flowchart install and configure home assistant in Docker

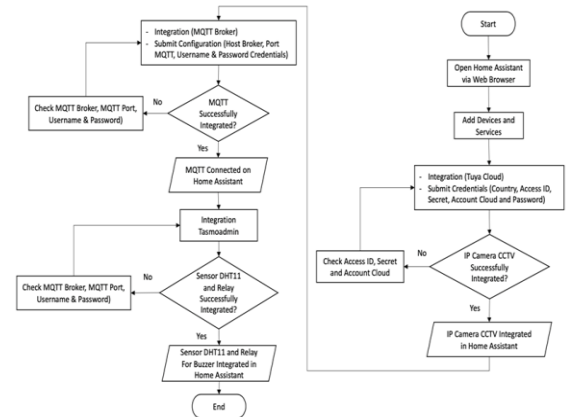

Fig 13 Flowchart integration of IP CCTV Camera, DHT11 Sensor and Buzzer Alarm in Home Assistant

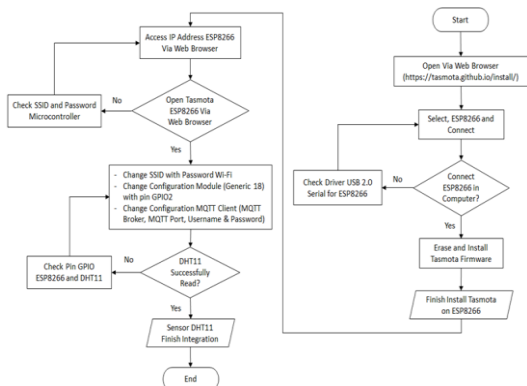

Fig 10 Flowchart install and configure Tasmota in integrated ESP8266 Microcontroller with DHT11 Sensor

7). *Research Procedure*

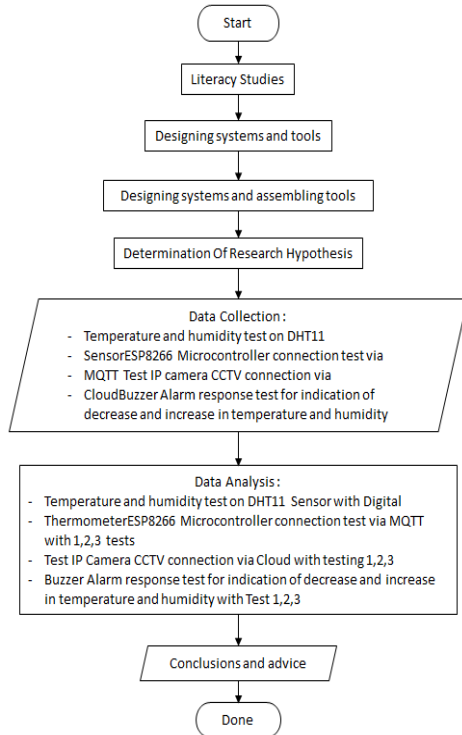

Fig 14 Research Procedure

B. *Product Test*

Testing is a process for systems and tools that are made to work properly. In accordance with the existing theory, there are several tests that will be carried out, among others:

1). *Temperature and Humidity test on DHT11 Sensor*

Testing was conducted in three server rooms, with the condition of the device in the server room operates. So that the results of reading data from the DHT11 sensor are sent to the cloud using the internet network via the MQTT protocol and display temperature and humidity readings in the Home Assistant.

Table 1 Microcontroller ESP8266 connection with DHT11 Sensor

| Microcontroller ESP8266 | Sensor DHT11 |
|-------------------------|--------------|
| D5 | Data |
| 3V | VCC |
| GND | GND |

2). *Microcontroller ESP8266 connection test via MQTT Protocol*

The tests were carried out using a device designed and integrated with the DHT11 Sensor. The purpose of this test is to find out how long the ESP8266 microcontroller is connected to MQTT and continues to connect to the Home Assistant via the internet network. In addition, this test ensures that the GPIO pin on the ESP8266 microcontroller

is connected to the sensor so that it functions according to the study.

3). *Test CCTV IP Camera connection via Cloud*

The test was carried out by displaying video Streaming IP CCTV cameras installed to monitor the condition and situation of the three server rooms. In addition, IP CCTV cameras are integrated with the Tuya IOT platform development cloud and display Streaming Video in the Home Assistant.

4). *Buzzer Alarm response test for indication of decrease and increase in temperature and humidity*

The test is done by automating the buzzer when the temperature and humidity experience a decrease and increase as a warning in certain conditions in each server room. In addition, a response test was carried out using notifications from the Home Assistant application to ensure that the buzzer installed in the IT room and data function in accordance with the results of the study.

Table 2 Microcontroller ESP8266 connection with Buzzer Relay

| Microcontroller ESP8266 | Modul Relay |
|-------------------------|-------------|
| D5 | IN |
| 3V | VCC |
| GND | GND |

C. *Variables and operational definition of variables*

In this study there are several variables that aim to get the results achieved. These variables are

- 1). DHT11 Sensor is a tool for measuring temperature and humidity in three server rooms of PGRI Adi Buana University Surabaya.
- 2). CCTV IP cameras are used to monitor conditions in three server rooms of PGRI Adi Buana University Surabaya.
- 3). Home Assistant is used to display temperature and humidity readings from DHT11 sensors and streaming video from IP CCTV cameras installed in three server rooms so that they can be monitored.
- 4). The ESP8266 Microcontroller is used to receive data from the DHT11 sensor and transmit that data to the Home Assistant via the MQTT protocol.

D. *Data Analysis Methods*

Data analysis methods used in this study include

- 1). The first stage, designing a temperature and humidity detector and Buzzer Alarm.
- 2). The second step is to implement the Home Assistant on a Virtual Private Server.

- 3). The third stage, the integration of Home Assistant with temperature and humidity detection devices and Buzzer alarms via the MQTT protocol. In addition, it also integrates IP CCTV cameras through the cloud.
- 4). The fourth stage, testing DHT11 sensors installed in three server rooms to measure temperature and humidity. The test is carried out using the MQTT protocol via the internet and the measurement results are displayed in the Home Assistant.
- 5). The fifth stage, testing video streaming on IP CCTV cameras installed in three server rooms via the cloud using the internet network and displaying the condition of the server room in the Home Assistant.
- 6). The sixth stage, testing the Buzzer Alarm as a warning in certain situations in each server room. In addition, a response test was carried out by sending a notification to the Home Assistant application to ensure that the buzzer installed in the IT and data Rooms is working properly.
- 7). The seventh stage, the overall test of integrated components

DHT11 sensor are then compared with the temperature and humidity readings in a digital thermometer. The temperature and humidity test results of the three server rooms are as follows

| Time Duration (Minutes) | Display of Thermometer | | Display of Home Assistant | | Error (Celcius) | |
|-------------------------|------------------------|----------|---------------------------|------------|-----------------|----------|
| | Detection | | Detection | | Detection | |
| | Temperature | Humidity | Temperature | Kelembaban | Temperature | Humidity |
| 10 | 22,0 | 52% | 21,4 | 52% | 0,6 | 0% |
| 20 | 22,4 | 50% | 21,0 | 48% | 1,4 | 2% |
| 30 | 21,8 | 50% | 20,6 | 46% | 1,2 | 4% |
| 40 | 21,8 | 48% | 20,2 | 45% | 1,6 | 3% |
| 50 | 21,6 | 48% | 21,0 | 44% | 0,6 | 4% |
| 60 | 21,8 | 47% | 21,4 | 43% | 0,4 | 4% |
| Average | 21,9 | 49% | 20,9 | 46% | 1 | 3% |

Table 3 Temperature and humidity test on DHT11 Sensor in the main Server room of Pgsd Building, second floor

Table 4 Temperature and humidity test on DHT11 Sensor in Backup server room of campus dated postgraduate building III floor

| Time Duration (Minutes) | Display of Thermometer | | Display of Home Assistant | | Error (Celcius) | |
|-------------------------|------------------------|----------|---------------------------|------------|-----------------|----------|
| | Detection | | Detection | | Detection | |
| | Temperature | Humidity | Temperature | Kelembaban | Temperature | Humidity |
| 10 | 21,0 | 48% | 20,6 | 46% | 0,4 | 2% |
| 20 | 21,6 | 48% | 21,0 | 45% | 0,6 | 3% |
| 30 | 21,8 | 46% | 21,4 | 44% | 0,4 | 2% |
| 40 | 21,4 | 50% | 20,6 | 49% | 0,8 | 1% |
| 50 | 21,4 | 49% | 20,2 | 47% | 1,2 | 2% |
| 60 | 21,0 | 48% | 21,0 | 45% | 0 | 3% |
| Average | 21,4 | 48% | 20,8 | 46% | 0,6 | 2% |

Table 5 Temperature and humidity test on DHT11 Sensor in Ngagel campus network Server room building a second floor

| Time Duration (Minutes) | Display of Thermometer | | Display of Home Assistant | | Error (Celcius) | |
|-------------------------|------------------------|----------|---------------------------|----------|-----------------|----------|
| | Detection | | Detection | | Detection | |
| | Temperature | Humidity | Temperature | Humidity | Temperature | Humidity |
| 10 | 21,4 | 40% | 20,6 | 39% | 0,8 | 1% |
| 20 | 21,2 | 40% | 20,6 | 40% | 0,6 | 0% |
| 30 | 21,8 | 42% | 21,8 | 41% | 0 | 1% |
| 40 | 22,8 | 41% | 22,2 | 40% | 0,6 | 1% |
| 50 | 21,6 | 44% | 21,0 | 44% | 0,6 | 0% |
| 60 | 21,6 | 43% | 21,4 | 43% | 0,2 | 0% |
| Average | 21,7 | 42% | 21,3 | 41% | 0,5 | 0% |

III. RESULTS AND DISCUSSION

A. Results and Product Evaluation

In the system design and manufacture of tools that can be used as a monitoring application to monitor the condition of three server rooms by the field of Information and Data Technology, PGRI Adi Buana University Surabaya. Monitoring applications can be accessed remotely using the internet network. There are several series of such devices, namely ESP8266 microcontroller, DHT11 sensor, and 5V adapter as a temperature and humidity detector. In addition, IP CCTV cameras are used to monitor the condition of three server rooms and buzzer alarms serve as warnings in certain situations in each server room. Home Assistant as a monitoring application, integrated with temperature and humidity detection devices and buzzer alarms connected via the MQTT protocol and IP CCTV cameras connected via the cloud.

B. Presentation of Data

Based on the experiments conducted, the analysis of the data obtained resulted in the following data

1). Temperature and Humidity test on DHT11 Sensor

Temperature and humidity testing is performed on the DHT11 sensor to determine the value of the data generated and the difference in data or error on the DHT11 sensor. Testing is carried out in a period of 10 minutes to 60 Minutes. The test phase was carried out by turning on the temperature and humidity detectors installed in three server rooms connected to the internet network and integrated into the Home Assistant. The test results of the

2). *Microcontroller ESP8266 connection test via MQTT Protocol*

Connection testing the ESP8266 microcontroller is connected to the Home Assistant via the MQTT protocol. The goal is to find out how long the ESP8266 microcontroller and Home Assistant are connected without disconnecting. Testing was carried out in 3 trials between 10 minutes to 60 Minutes. The test step was carried out by turning on the temperature and humidity detectors installed in the three server rooms and buzzer alarms installed in the IT and data rooms. Each device is connected to the internet, then integrated into the Home Assistant via the MQTT protocol. The test results of the ESP8266 microcontroller connection in three server rooms and in the IT and data rooms via the MQTT protocol are as follows

Table 6 ESP8266 microcontroller connection test via MQTT protocol

| Testing | Time Duration (Minutes) | ESP8266 microcontroller connection test via MQTT protocol | | | | Error Connecti on MQTT |
|---------|-------------------------|---|--------------------|---------------------|------------------|------------------------|
| | | Main Server Room | Backup Server Room | Network Server Room | TI dan Data Room | |
| | | Sensor DHT11 | Sensor DHT11 | Sensor DHT11 | Alarm Buzzer | |
| 1 | 10 s/d 60 | √ | √ | √ | √ | - |
| 2 | 10 s/d 60 | √ | √ | √ | √ | - |
| 3 | 10 s/d 60 | √ | √ | √ | √ | - |

3). *Test CCTV IP Camera connection via Cloud*

IP Camera CCTV connection testing using API service in cloud Tuya IOT platform development for data transmission. The purpose of this test is to find out how long the CCTV IP Camera is connected to the cloud without disconnecting. Testing is carried out in 3 times with a period of 10 minutes to 60 Minutes. The testing phase was carried out by turning on IP CCTV cameras installed in three server rooms. Then it is integrated into the Home Assistant and each CCTV IP Camera is connected to the internet network. The test results of CCTV IP Camera connection in three server rooms are as follows

Table 7 Test CCTV camera IP connection via Cloud

| Testing | Time Duration (Minutes) | Test CCTV IP Camera connection via Cloud | | | Error Connection |
|---------|-------------------------|--|--------------------|---------------------|------------------|
| | | Main Server Room | Backup Server Room | Network Server Room | |
| | | IP Camera CCTV | IP Camera CCTV | IP Camera CCTV | |
| 1 | 10 s/d 60 | √ | √ | √ | - |
| 2 | 10 s/d 60 | √ | √ | √ | - |
| 3 | 10 s/d 60 | √ | √ | √ | - |

4). *Buzzer Alarm response test for indication of decrease and increase in temperature and humidity*

Buzzer alarm responsiveness test for warning at the time of decrease and increase in temperature and humidity aims to determine the limit value that has been set, namely the temperature of 20-25% and humidity in three server rooms so that the buzzer alarm installed in the IT room and the data will light up beyond the limit value that has been determined. The tests were conducted in 3 experiments between 10 minutes to 60 minutes at the time of decrease and increase in temperature and humidity in each DHT11 sensor installed in three server rooms. The test step is performed by turning on the ESP8266 microcontroller installed with a buzzer alarm. Then it is integrated into the Home Assistant and the buzzer alarm is connected to the internet network. The results of the responsiveness and warning test on the buzzer alarm are as follows

Table 8 Test the responsiveness and warning of the Buzzer Alarm from the DHT11 Sensor in the main Server room of the campus on the second floor of the PGSD building

| Condition | Main Server Room | | | | Duration (Response) |
|---|------------------|----------|-------------------|--------------|---------------------|
| | Temperature | Humidity | App Notifications | Alarm Buzzer | |
| Normal | 21,0 | 42% | Inactive | Off | - |
| Drop | 25,8 | - | Active | On | 0,53 |
| | 25,6 | - | Active | On | 0,47 |
| | 25,2 | - | Active | On | 0,46 |
| | - | 39% | Active | On | 0,44 |
| | - | 39% | Active | On | 0,46 |
| Increase | - | 39% | Active | On | 0,57 |
| | 19,8 | - | Active | On | 0,57 |
| | 19,9 | - | Active | On | 0,54 |
| | 19,9 | - | Active | On | 0,49 |
| | - | 46% | Active | On | 0,52 |
| | - | 46% | Active | On | 0,59 |
| Average speed of responsiveness and warning on the Buzzer Alarm | | | | | 0,51 |

Table 9 Responsiveness test and Buzzer Alarm warning from DHT11 Sensor in campus Backup Server room dated postgraduate building III floor

| Condition | Backup Server Room | | | | Duration (Response) |
|---|--------------------|----------|-------------------|--------------|---------------------|
| | Temperature | Humidity | App Notifications | Alarm Buzzer | |
| Normal | 21,5 | 46% | Inactive | Off | - |
| Drop | 25,6 | - | Active | On | 0,47 |
| | 25,4 | - | Active | On | 0,47 |
| | 26,2 | - | Active | On | 0,53 |
| | - | 39% | Active | On | 0,47 |
| | - | 39% | Active | On | 0,46 |
| Increase | 19,8 | - | Active | On | 0,53 |
| | 19,9 | - | Active | On | 0,59 |
| | 19,8 | - | Active | On | 0,45 |
| | - | 46% | Active | On | 0,56 |
| | - | 46% | Active | On | 0,47 |
| Average speed of responsiveness and warning on the Buzzer Alarm | | | | | 0,50 |

Table 10 Test the responsiveness and warning of the Buzzer Alarm from the DHT11 Sensor in the Ngagel campus network Server room building a second floor

| Condition | Network Server Room | | | | Duration (Response) |
|---|---------------------|----------|-------------------|--------------|---------------------|
| | Temperature | Humidity | App Notifications | Alarm Buzzer | |
| Normal | 22,0 | 40% | Inactive | Off | - |
| Drop | 25,2 | - | Active | On | 0,52 |
| | 25,6 | - | Active | On | 0,59 |
| | 25,4 | - | Active | On | 0,46 |
| | - | 39% | Active | On | 0,53 |
| | - | 39% | Active | On | 0,46 |
| Increase | 19,9 | - | Active | On | 0,54 |
| | 19,9 | - | Active | On | 0,54 |
| | 19,9 | - | Active | On | 0,48 |
| | - | 46% | Active | On | 0,56 |
| | - | 46% | Active | On | 0,52 |
| Average speed of responsiveness and warning on the Buzzer Alarm | | | | | 0,52 |

C. Data Analysis

1). Temperature and Humidity test on DHT11 Sensor

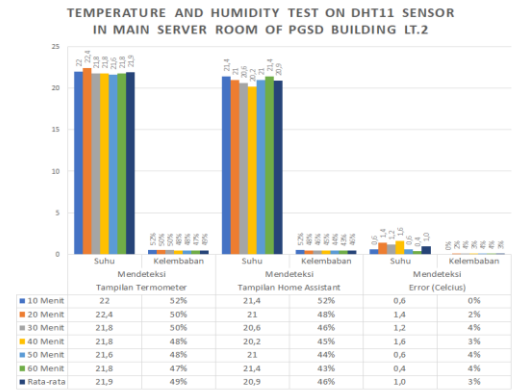

Fig 15 Temperature and humidity test on DHT11 Sensor in the main Server room of the campus on the second floor of PGSD building

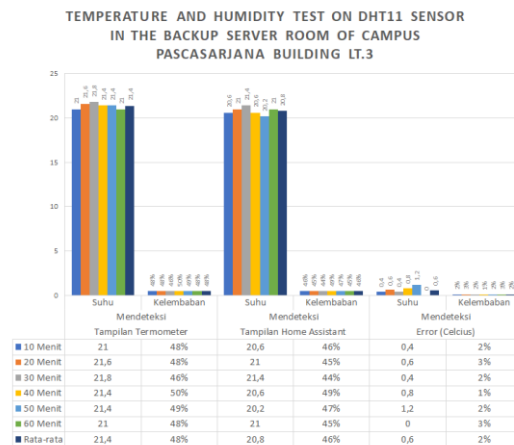

Fig 16 Temperature and humidity test on DHT11 Sensor in Backup server room of campus dated postgraduate building III floor

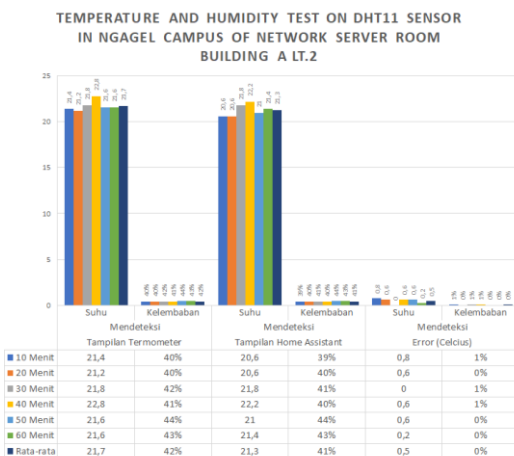

Fig 17 Temperature and humidity test on DHT11 Sensor in Ngagel campus network Server room building a second floor

2). *Microcontroller ESP8266 connection test via MQTT Protocol*

Table 11 ESP8266 Microcontroller connection test through MQTT protocol in three Server rooms and it and Data Rooms of PGRI Adi Buana University Surabaya

| Location | Trial to- | Duration Of Testing | | | | | | Description |
|---|-----------|---------------------|----|----|----|----|----|---|
| | | Minutes | | | | | | |
| | | 10 | 20 | 30 | 40 | 50 | 60 | |
| Main Server Room of Campus Menanggal Building PGSD Lt.2 | 1-3 | √ | √ | √ | √ | √ | √ | The test was successful, the ESP8266 Microcontroller was successfully connected to the Home Assistant |
| Backup Server Room of Campus Menanggal Building Pascasarjana Lt.3 | 1-3 | √ | √ | √ | √ | √ | √ | |
| Network Server Room of Campus Ngagel Building A Lt.2 | 1-3 | √ | √ | √ | √ | √ | √ | |
| TI dan Data Room of Campus Menanggal Building PGSD LT.1 | 1-3 | √ | √ | √ | √ | √ | √ | |

3). *Test CCTV IP Camera connection via Cloud*

Table 12 Test CCTV IP Camera connection via cloud in three Server rooms of PGRI Adi Buana University Surabaya

| Location | Trial to- | Duration Of Testing | | | | | | Description |
|---|-----------|---------------------|----|----|----|----|----|--|
| | | Minutes | | | | | | |
| | | 10 | 20 | 30 | 40 | 50 | 60 | |
| Main Server Room of Campus Menanggal Building PGSD Lt.2 | 1-3 | √ | √ | √ | √ | √ | √ | Testing was successful, CCTV IP Camera connected to Home Assistant |
| Backup Server Room of Campus Menanggal Building Pascasarjana Lt.3 | 1-3 | √ | √ | √ | √ | √ | √ | |
| Network Server Room of Campus Ngagel Building A Lt.2 | 1-3 | √ | √ | √ | √ | √ | √ | |

4). *Buzzer Alarm response test for indication of decrease and increase in temperature and humidity*

AVERAGE BUZZER ALARM RESPONSE SPEED AT THE TIME OF DECREASE AS WELL AS INCREASE IN DHT11 SENSORS IN IT AND DATA ROOMS

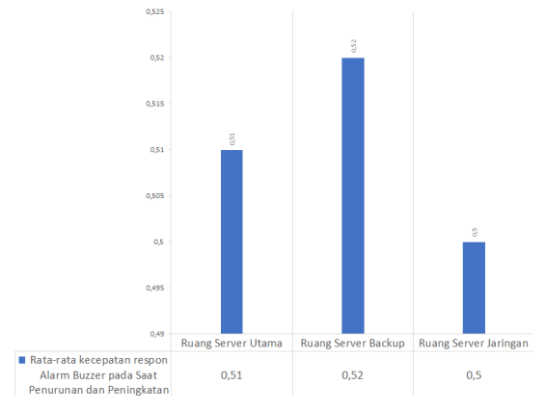

Fig 18 Responsiveness test and warning Buzzer Alarm from DHT11 Sensor in three Server rooms of PGRI Adi Buana University Surabaya

D. *Discussion*

Testing is carried out in several test scenarios where the devices and communication protocols used are tested. From the test results compare the temperature and humidity on the DHT11 sensor with a digital thermometer. Based on the test results, in Table 4.2.1 the test results of temperature and humidity on the DHT11 sensor in the main server room of the campus on the second floor of the pgsd building have an average value of the DHT11 sensor is 20.9% of the temperature and 48% of the humidity. While the difference in data from the DHT11 sensor and digital thermometer with data error of 1% on temperature and 3% on humidity. In Table 4.2.2 the test results of temperature and humidity on the DHT11 sensor in the backup server room of the campus on the third floor of the postgraduate building have an average value of the DHT11 sensor is 21.3% at temperature and 41% at humidity. While the difference in data from the DHT11 sensor and digital thermometer with a data error of 0.5 degrees at temperature and 0% at humidity. In Table 4.2.3 the test results of temperature and humidity on the DHT11 sensor in the campus network server room ngagel building a second floor has an average value of the DHT11 sensor is equal to 20.8% C at temperature and 46% at humidity. While the difference in data from the DHT11 sensor and digital thermometer with data error of 0.6% on temperature and 2% on humidity. Testing the connection of ESP8266 microcontroller to Home Assistant installed in three server rooms as well as it and data rooms, able to connect to Home Assistant via MQTT protocol well up to 3 attempts with a period of 60 minutes without problems. In addition to testing the ESP8266 microcontroller connection, there are tests of CCTV IP cameras installed in three server rooms and connected to the Home Assistant via the cloud with testing 3 times in a period of 60 minutes without experiencing problems. So that it can

monitor every condition in the three server rooms of PGRI Adi Buana University Surabaya. The results of the test of responsiveness and warning buzzer alarm at the time of decrease and increase in temperature and humidity in each DHT11 sensor installed in three server rooms, the results of this test the average speed of response buzzer alarm and notification on the application is 0.51 seconds on the DHT11 sensor installed in the main server room, 0.52 seconds on the DHT11 sensor installed in the backup server room and 0.5 seconds on the DHT11 sensor installed in the network server room. Each DHT11 sensor sends a value beyond a predetermined limit so that the buzzer alarm installed in the IT room and data are successfully activated.

IV. CONCLUSION

From a series of research, testing and analysis of temperature and humidity Detection System Design based on Internet of Things (IoT) in the Server room of PGRI Adi Buana University Surabaya can be concluded as follows

- 1). Temperature and humidity detection system helps monitoring in the server room of PGRI Adi Buana University Surabaya.
- 2). At Home Assistant uses a public IP so that it can be accessed remotely by IT personnel to monitor conditions in three server rooms simultaneously.
- 3). DHT11 Sensor installed in the main Server room of the campus on the second floor of the PGSD building obtained data when detecting temperature and humidity with an average temperature of 20.9% and 48% in humidity. While the difference in data from the DHT11 sensor and digital thermometer with data error of 1% on temperature and 3% on humidity.
- 4). The DHT11 Sensor installed in the Backup server room of the campus on the third floor of the Postgraduate building obtained data when detecting temperature and humidity with an average temperature of 21.3% and 41% humidity. While the difference in data from the DHT11 sensor and digital thermometer with a data error of 0.5 degrees at temperature and 0% at humidity.
- 5). DHT11 Sensor installed in the campus network server room Ngagel building a second floor data obtained when detecting temperature and humidity with an average temperature of 20.8% C in temperature and 46% in humidity. While the difference in data from the DHT11 sensor and digital thermometer with data error of 0.6% on temperature and 2% on humidity.
- 6). ESP8266 microcontroller data communication installed in the main Server room, campus Menanggal Pgsd Building second floor; Backup Server room, campus Menanggal postgraduate building third floor; Network Server Room, campus

Ngagel building a second floor; and it and Data Room, campus Menanggal Pgsd building first floor connected to Home Assistant via MQTT protocol well up to 3 trials with a period of 60 minutes without problems.

- 7). IP Camera CCTV installed in the main Server room, campus Menanggal Pgsd Building second floor; Backup Server room, campus Menanggal postgraduate building third floor; and network Server room, campus Ngagel building a second floor connected to the Home Assistant to monitor conditions in the server room by utilizing the API service on the cloud and running well.
- 8). The Buzzer Alarm installed in the IT and data rooms was successfully activated without problems when the DHT11 sensors installed in the three server rooms sent values outside the specified limits during the decrease and increase in temperature and humidity. The average speed of responsiveness and warning on the buzzer alarm and notification in the application is 0.51 seconds from the DHT11 sensor installed in the main server room, 0.52 seconds on the DHT11 sensor installed in the backup server room and 0.5 seconds on the DHT11 sensor installed in the network server room

REFERENCES

- [1] Fatra, D., & Syazili, A. (2021, November). Sistem Monitoring Suhu Jarak Jauh pada Ruang Server berbasis Internet of Things. In *Bina Darma Conference On Computer Science (BDCSS)* (Vol. 3, No. 2, Pp. 401-408).
- [2] Gunawan, G., & Fatimah, T. (2020). Implementasi Sistem Pengaturan Suhu Ruang Server menggunakan Sensor DHT11 dan Sensor PIR berbasis Mikrokontroler. *Edumatic: Jurnal Pendidikan Informatika*, 4(1), 101-110.
- [3] Kurniawan, M. C., & Setyawan, B. (2021). Rancang Bangun Sistem Monitoring Suhu dan Kelembaban Ruang Server pada PT. Untung Bersama Sejahtera Surabaya. *Jurnal Ilmiah Scroll (Jendela Teknologi Informasi)*, 4(1).
- [4] Raharjo, E. B., Marwanto, S., & Romadhona, A. (2019). Rancangan Sistem Monitoring Suhu dan Kelembapan Ruang Server berbasis Internet of Things. *Teknika*, 6(2), 61-68.
- [5] Satyadi, W., & Siswanto, S. (2018). Aplikasi Monitoring dan Kendali Suhu Panas Ruang Server menggunakan Sensor DHT22, Sensor Gerak PIR, Mikrokontroler Arduino Uno R3 dan Cc3000 Wifi dengan Notifikasi Email. *SKANIKA*, 1(3), 1229-1236.
- [6] Srivastava, D., Kesarwani, A., & Dubey, S. (2018). Measurement of Temperature and Humidity by using Arduino Tool and DHT11. *International Research Journal of Engineering and Technology (IRJET)*, 5(12), 876-878.
- [7] Waworundeng, J. M. S., Dumanaw, O., & Rumawouw, T. (2021). Prototipe Detektor Suhu dan Kelembaban Berbasis IoT di Ruang Server Sistem Informasi Universitas Klatat. *CogITO Smart Journal*, 7(1), 193-203.
- [8] Yio, E. S. (2018). Perancangan dan Implementasi CCTV Online Menggunakan IP Camera di PT. Pancar Sinar Abadi (Doctoral dissertation, Sistem Informasi).
- [9] Yunarti, S., & Baharuddin, S. H. (2017). Perancangan Sistem Pengukur Suhu pada Ruang Server menggunakan Raspberry Pi dan Sensor Suhu DHT11. *Siberpro*, 2(2), 23-36.