

Temperature Control System on Aquascape using On-Off Control

Widodo

Department of Electrical Engineering
University of PGRI Adi Buana Surabaya
widodo@unipasby.ac.id

Rudi Setiawan

Department of Electrical Engineering
University of PGRI Adi Buana Surabaya
setiawan182rudi@gmail.com

Abstract—Every human being has a feeling of saturation in carrying out his daily activities. There are many ways you can do to get rid of boredom, one of which is by doing hobbies that we like. Currently there are many hobbies that can be done, one of which is a hobby of decorating an aquarium (Aquascape) by using stones, wood, sand and using water plants. Which is starting to be of interest to various circles of society. For Aquascape owners, sometimes their daily activities are busy. In fact, these other activities can take up to days. The solution to the problem of fan negligence when maintaining the Aquascape is to build an aquarium system that can adjust the lighting periodically as needed, stabilizing the water temperature in the aquarium.

Keywords : Aquascape, Temperature, and On-Off Control

I. INTRODUCTION

Every human being has a feeling of saturation in carrying out his daily activities. There are many ways you can do to get rid of boredom, one of which is by doing hobbies that we like. Currently there are many hobbies that can be done, one of which is a hobby of decorating an aquarium (aquascape) by using stones, wood, sand and using water plants. Which is starting to be of interest to various circles of society.

The main component in the aquarium (aquascape) aquatic plants. Taking care of aquatic plants requires persistence in keeping them healthy. There are several factors that must be considered in aquatic plants, stable temperature and sufficient lighting so that the plant photosynthesis process runs well. However, there are a lot of aquascape fans who don't pay attention to these conditions. For aquascape owners,

sometimes their daily activities are busy. In fact, these other activities can take up to days. This situation can cause the process of feeding fish, oxygen and light that is not sufficiently according to schedule and portions.

By writing device control commands to the microcontroller device, it can control and monitor water temperature and lighting time according to the needs of aquatic plants automatically.

The solution to the problem of fan negligence when maintaining an aquascape is to build an aquarium system that can adjust lighting periodically as needed, stabilizing the water temperature in the aquarium. In this study, the authors set the temperature and lighting automatically. Therefore, the authors propose a study entitled "Temperature Control System in Aquascape Based On-off Control".

II. METHODS

On-off Control System

Controllers *on-off* (controller two positions) are controllers that change alternately between the two conditions. In some cases, these are really "on" and "off" positions. Control *On-Off* is relatively simple and cheap, therefore it is widely used in industry and in houses. This controller is widely used as in electric irons, temperature control systems room, and fridge, air control systems, and refrigerators [3].

For example, the controller output signal is $m(t)$, and the error is $e(t)$. On the on-off control, signal $m(t)$ will remain at the maximum or minimum value, depending on the signal sign driving error, positive or negative.

Mathematically, the on-off control system is stated as follows

$$\begin{aligned} m(t) &= M1 \text{ if } e(t) < 0 \\ &= M2 \text{ if } e(t) > 0 \end{aligned}$$

Disadvantages and Pros of On-off Control

Advantages

1. Simple system installation.
2. Cheap manufacturing costs.

Deficiency

1. The gluing is quickly damaged by repeated on and off positions.
2. It can't reach the desired value, just oscillate around the desired value.

DS18B20 Temperature Sensor

Most temperature sensors have a narrow rated range and low accuracy but have a high cost. The DS18B20 temperature sensor with waterproof capability is suitable for measuring temperatures in difficult or wet places. Because the output of this sensor data is digital data, there is no need to worry about data degradation when using for long distances. The DS18B20 provides 9 bits to 12 configurable data bits. Because each DS18B20 sensor has a unique silicon serial number, multiple DS18B20 sensors can be installed on one bus. This allows temperature readings from multiple places. Although the datasheet this sensor can read well up to 125 ° C, with a PVC cable cover it is recommended for use not to exceed 100 ° C.



Fig. 1. DS18B20 Temperature Sensor

1. Arduino

Arduino is an open-source single-board micro controller, designed to facilitate the use of electronics in a variety of fields. Arduino hardware has an Atmel AVR processor and uses its own software and language.

Arduino is an electronic kit or opensource electronic circuit board in which there is a main component, namely a microcontroller chip with the AVR type from the Atmel company [4].

2. Relay

Relay is an electronic component that functions to disconnect or connect one electronic circuit with another electronic circuit. Basically, a relay is a switch that works based on the principle of a magnetic magnet that will work when the current flows through the coil, the iron core will become a magnet and will attract the contacts in the

relay. Contact can be drawn when the magnetic line can beat the opposing spring force.

The magnitude of the magnetic force is determined by the magnetic field present in the air gap, the anchor, the magnetic core, the number of turns of the coil, the strength of the flowing current (imperallilant) and the magnetic Palawan that is on the magnetic circuit [1].



Fig. 2. Relay

3. Cooling Fan

The recommended / required temperature in aquascaping is in the range of 22 ° -24 ° C (if you do not use biota that is resistant to very cold temperatures) when using fish and other biota, the ideal temperature is in the range of 24 ° -28 ° C. otherwise the ideal temperature is in the range of 24 ° -28 ° C.

For areas or cities that are hot, of course, it will be difficult to get the recommended temperature, such as the optimal highest temperature reaching 30 ° C and sometimes other factors that can affect the temperature increase are the heat from the lighting, so that who have more money can use it. When using a large aquarium chiller or with other solutions, if the aquarium used is not too large, a cooling fan can be used.



Fig 3. Cooling Fan

II. METHODS

This study uses an experimental research method (trial). The purpose of this study was to obtain the design results of the DS18B20 temperature sensor measurements, which are used to adjust the temperature of the water in the aquascape. This experimental research is conducted on system design, both in hardware design and software design of this tool.

1. Block Diagram System

Before making a tool, of course, a plan is needed so that the tool will be in accordance with what is expected. So in planning the tool, it is necessary to make a block diagram. The block diagram is a planning framework which will then be developed more specifically at a later stage.

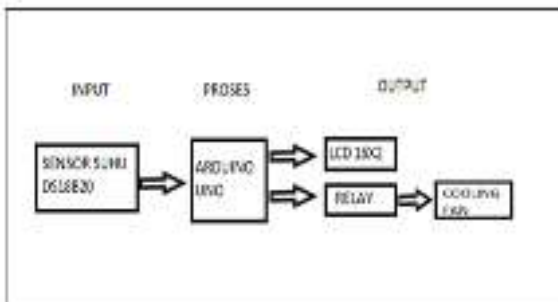

Fig. 4. Overall System Block Diagram

In planning this tool is designed to use input in the form of a temperature sensor and a water turbidity sensor. This system uses the main controller in the form of an Arduino Uno 328 microcontroller. Then it is displayed with an LCD to monitor the sensor readings.

For the hardware implementation design, the location of the Arduino Uno and the relay will be put into an acrylic box measuring 11cm x 7cm x 7cm, which will be placed in the black box at the back of the aquarium.

2. Flow Chart

The flow diagram illustrates the work flow of the On-off Control-Based Temperature Control System in the Aquascape. The way this Water Temperature Meter works starts from the Dallas DS18B20 sensor input which functions as a water temperature reading sensor. The measurement result data will be displayed on the LCD, then the measurement result data will be stored in the database. The work flow chart of the On-off Control-Based Temperature Control System in Aquascape is shown in Figure 5.

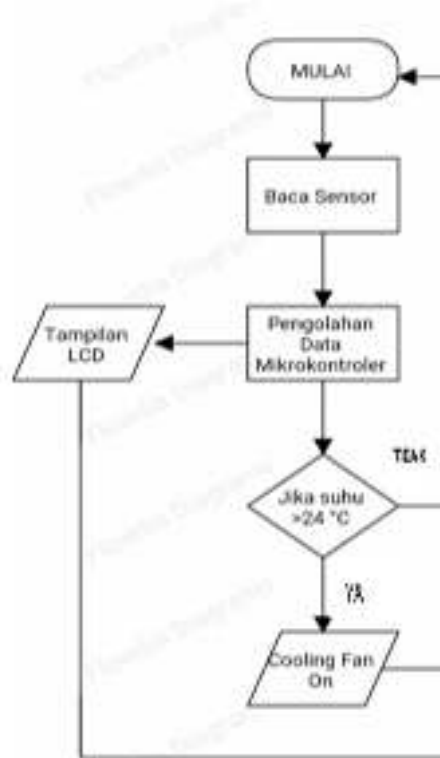

Figure 5. Flow diagram

3. Circuit Schematic

The circuit schematic is a blueprint of the tool model to be made. The overall circuit scheme for a water temperature measuring instrument based on the Arduino Uno microcontroller, the Dallas DS18B20 sensor as a temperature sensor, the cooling fan as an indicator on the tool and the LCD as a place to display measurement data directly. The schematic of a circuit for measuring water temperature can be seen at

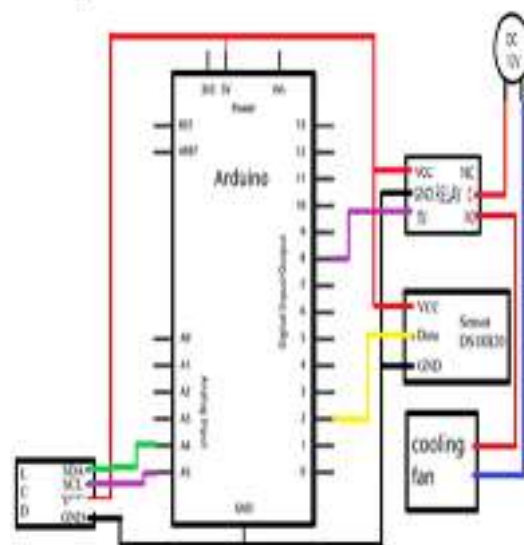

Figure 6. Circuit Schematic

III. RESULTS AND DISCUSSION

DS18B20 temperature sensor testing

Sensor testing aims to determine whether the sensor can measure the temperature of the aquascape water properly. The test was carried out under two different conditions. The first test was carried out in an open space during the day with 5 data retrieval. The second test was carried out in a closed room with a room temperature of ± 33 C. with 3 data retrieval. The following is a table of test results for the DS18B20 temperature sensor. The DS18B20 temperature sensor measurement data compared to the calibrator temperature is shown in Table 1 and Table 2. Based on the data in Table 4.1 and Table 4.2, graphs are obtained as shown in Figure 4.2 and Figure 4.3.

Table 1. DS18B20 test data to 1

Temp. Air	Waktu	Temp. DS18B20 (°C)	Temp. pengukur lain (°C)	Selisih (°C)	Error (%)
1	14.05	32.2	32.8	0.6	0.00
	14.25	32.4	32.2	0.2	0.30
	14.50	32.7	32.8	0.1	0.47
	14.55	32.7	32.2	0.5	0.37
	15.00	32.9	32.5	0.4	0.37
Rata-rata				0.36	0.35

Table 2. 2nd DS18B20 test data

Temp. Air	Waktu	Temp. DS18B20 (°C)	Temp. pengukur lain (°C)	Selisih (°C)	Error (%)
1	15.30	32.8	32.8	0.0	0.00
	15.55	32.8	32.8	0.0	0.00
	16.00	32.9	32.5	0.4	0.37
Rata-rata				0.2	0.35

Table 3. LCD Display Test Results based on sensors

No	Tanggal	Ekstir (WIB)	Suhu Awal (°C)	Suhu Akhir (°C)	Perbedaan suhu suhu awal dengan suhu akhir (°C)
1	15-07-2021	06.10-07.10	29	25	4
		12.10-13.10	31	25	5
		20.10-21.10	30	25	5
4	15-07-2021	06.10-07.10	28	25	3
		12.10-13.10	29	25	4
		20.10-21.10	30	24	5
7	16-07-2021	06.10-07.10	29	25	4
		12.10-13.10	32	25	6
		20.10-21.10	31	25	6
10	15-07-2021	06.10-07.10	30	25	5
		12.10-13.10	30	25	5
		20.10-21.10	31	25	6
13	16-07-2021	06.10-07.10	30	26	4
		12.10-13.10	30	25	4
		20.10-21.10	31	25	6
16	17-07-2021	06.10-07.10	30	26	4
		12.10-13.10	30	25	5
		20.10-21.10	30	24	6
19	18-07-2021	06.10-07.10	30	25	5
		12.10-13.10	32	27	5
		20.10-21.10	31	26	5

Based on the data obtained in this study, data analysis was carried out in stages and was careful and thorough. With the analysis of the data obtained, the following results:

1. Test whether the Arduino Uno microcontroller when programmed can receive information from the DS18B20 TEMPERATURE sensor and send information to the LCD.
2. Test the sensor if it is working properly by comparing the sensor with a digital thermometer
3. Test whether the RTC program can run properly and can adjust the lights according to the program.
4. Test whether the LCD and sensors are functioning properly or not.
5. Test as a whole each component part is working properly by operating the entire program.

IV. CONCLUSION

After the researchers conducted experiments on the On-off Control-Based Temperature Control System in Aquascape. Based on these experiments, the following conclusions are obtained: The temperature control system in the aquascape can work optimally to reduce the temperature to 25 ° Celsius in an aquarium with a size of p = 31cm, l = 19cm, and a height of 25cm. Factors that affect the temperature in the aquarium are the temperature in the room and the temperature produced by the lights.

The water temperature does not reach 24 ° C due to the dry season and the high temperature around the aquascape.

ACKNOWLEDGMENT

I would like to thank Allah SWT and both parents and the supervisor lecturers of the PGRI Adi Buana University Surabaya, Faculty of Engineering, especially the Electrical Engineering study program, and friends of Electrical Engineering students who always gave enthusiasm and motivation for the completion of this article.

REFERENCES

- [1] Astriani Romania Saragih, 2016. Design of Automatic Fish Feeding Equipment for Fish Hatchery Based
- [2] on Arduino. Haji Tanjung, Raja Ali Pinang Maritime University.
- [3] B. Customo. 2015. Introduction to Arduino and Programming. Bandung, Bandung Informatics.
- [4] Ogata, Katsuhiko. 1984. Automatic Control Technique. Erlangga: Bandung
- [5] Syahwil, M. 2013. Arduino microcontroller. Yogyakarta: CV Andi OFFSET.
- [6] Sujiwa, Akbar, and Sagita Rochman. "Pengembangan Sistem Kontrol Serta Monitoring Suhu dan Volume Air Berbasis Web Pada Perangkat Desalinasi Air Laut." *SNHRP* (2019): 1-9.
- [7] Rochman, Sagita, and Bagus Ilham Yudianto. "PROTOTYPE AUTOMATIC LIGHTS CONTROL SYSTEM IN THE MOSQUE AREA BASED ON ARDUINO NANO." *BEST: Journal of Applied Electrical, Science, & Technology* 1.1 (2019): 32-35.
- [8] Rochman, Sagita, and M. Nushron Ali Mukhtar. "CLASSIFICATION OF THE QUALITY OF HONEY USING THE SPECTROFOTOMETER AND MACHINE LEARNING SYSTEM BASED ON SINGLE BOARD COMPUTER." *Tibuana* 2.01 (2019): 45-49.